

Bevel gearboxes

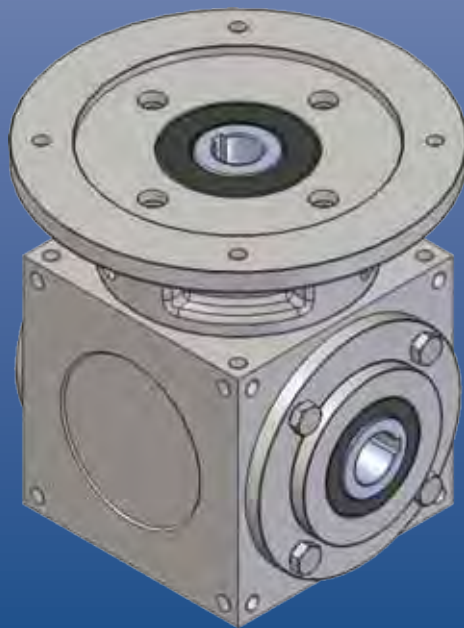

Bevel gearboxes BG Series

SERVOMECH
bevel gearboxes
in lifting systems

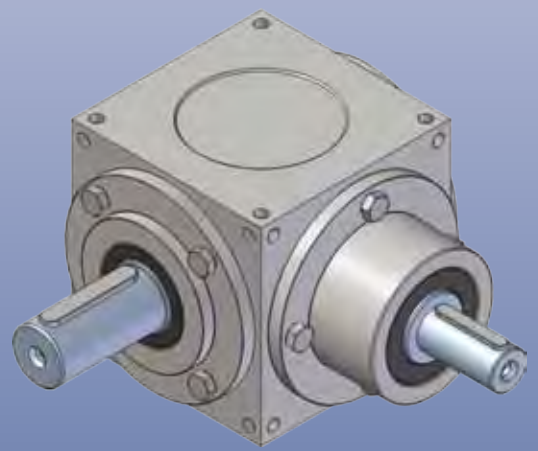
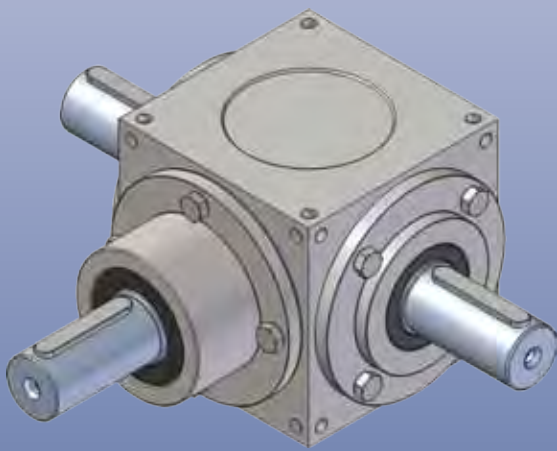
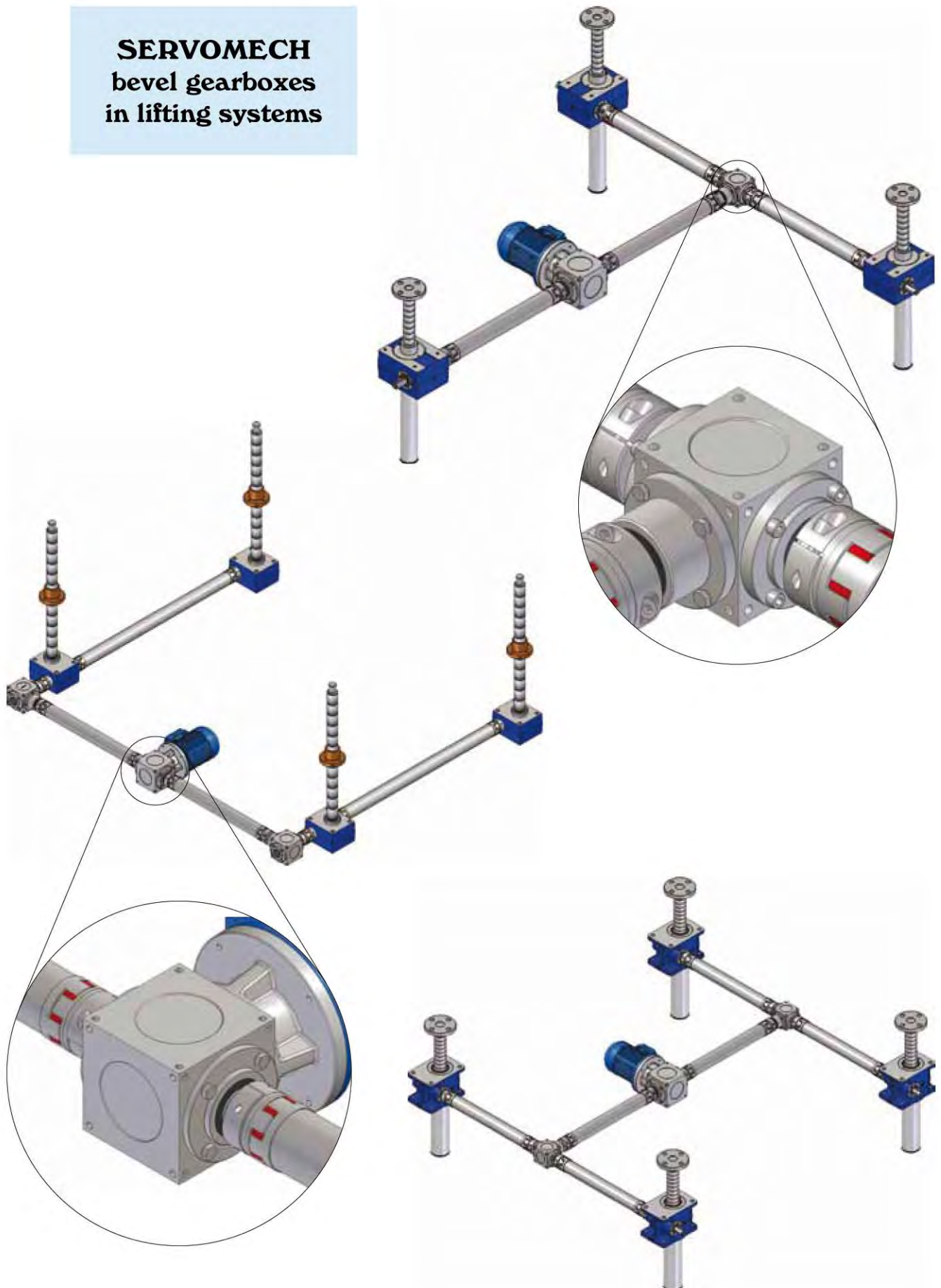

INDEX

Bevel gearbox description	page 2
Manufacturing features	page 2
Materials and components	page 4
Bevel gearbox selection	page 5
Thermal power limit	page 7
Design	page 8
Technical features summary	page 10
Nominal performances – torque and power	page 12
Identification of bevel gearbox housing sides	page 14
Bevel gearbox input: type and designation	page 14
Bevel gearbox main output: type and designation	page 15
Bevel gearbox additional output: type, designation and position	page 15
Overall dimensions	page 16
Special arrangements	page 27
Mounting and operating position	page 28
Kinematic scheme - Directions of shaft rotation	page 30
Bevel gearbox efficiency	page 37
Angular backlash	page 37
Radial and axial forces on the shafts	page 37
Moment of inertia of rotating mass	page 38
Ordering code	page 39
Product label	page 40
Lubrication and maintenance	page 41
Spare parts	page 42
General deliveries conditions	page 44
General sales terms	page 44
Bevel gearboxes in lifting systems	page 44

© Copyright SERVOMECH

This catalogue contents are under publisher copyright and may not be reproduced unless permission is agreed. Every care has been taken to ensure the accuracy of the information contained in this catalogue, but no liability can be accepted for any errors or omissions.

Bevel gearboxes BG Series

Bevel gearboxes description

The SERVOMECH s.p.a. bevel gearboxes BG Series is the result of an accurate and modern design technology and of the precise calculation of each single component and its assembling, which allows to ensure the declared performances with a high safety factor. Their development and production, totally “Made in Italy”, are carried out following the quality management procedures that SERVOMECH s.p.a. has adopted inside the company according to the UNI EN ISO 9001:2008 norm (the compliance of the quality management system to this standard is certified by TÜV). The robust and compact design and the high technology of the components allow high performances within small overall dimensions. The bevel gearboxes are suited also for operation with high input speed, up to 3000 rpm, with low noise level and high efficiency. The cubic shaped housing is machine finished on each side, allowing the highest flexibility in positioning and mounting.

The modular system makes different versions available, with additional outputs up to 6 shafts.

Design forms available with solid input and output shafts, with solid input shaft and hollow output shaft, hollow input shaft and flange for electric or hydraulic motor.

Several constructive designs allow the realization of different kinematic schemes to adapt the directions of the rotation as required by the application.

Output shaft angular backlash: standard max. 10 arcmin; on request controlled and reduced backlash, averagely less than (5 ... 6) arcmin.

Tapered roller bearings standard on all solid shafts and hollow output shaft; ball bearings on hollow input shafts for motor flange execution.

Long-life grease lubrication for applications with low input speed (see table on page 41) and not exceeding the thermal power limit.

Synthetic oil lubrication on request and in case of input speed as shown in the table on page 41.

Manufacturing features

- cubic shaped housing with 6 sides, each of them with 4 mounting threaded holes;
- all covers and shaft hubs are machined with centring diameter with outward tolerance **f7** to allow the central location of horizontal positioning or of adapter flange if required by the application;
- radial lubricant seals between rotating shafts and covers or shaft hubs or flange;
- O-ring as lubricant seal between housing and flange or shaft hub;
- shim washers on all input and output shafts to allow the correct positioning of the bevel gears;
- bevel gears made in high quality alloy steel, cut according to GLEASON spiroidal toothing system, case-hardened, tempered and lapped in pairs; the accurate and consolidated manufacturing technology allows to produce bevel gears able to work with low noise level and with high efficiency;
- solid and hollow shafts made from hardened steel bars, ground mounting dimensions;
- assembling carried out entirely inside the company SERVOMECH, following all procedure steps to ensure a precise adjustment of the bearings and of the bevel gears to exalt following performances:
 - noiseless operation
 - high efficiency
 - long service life

Bevel gearboxes BG Series

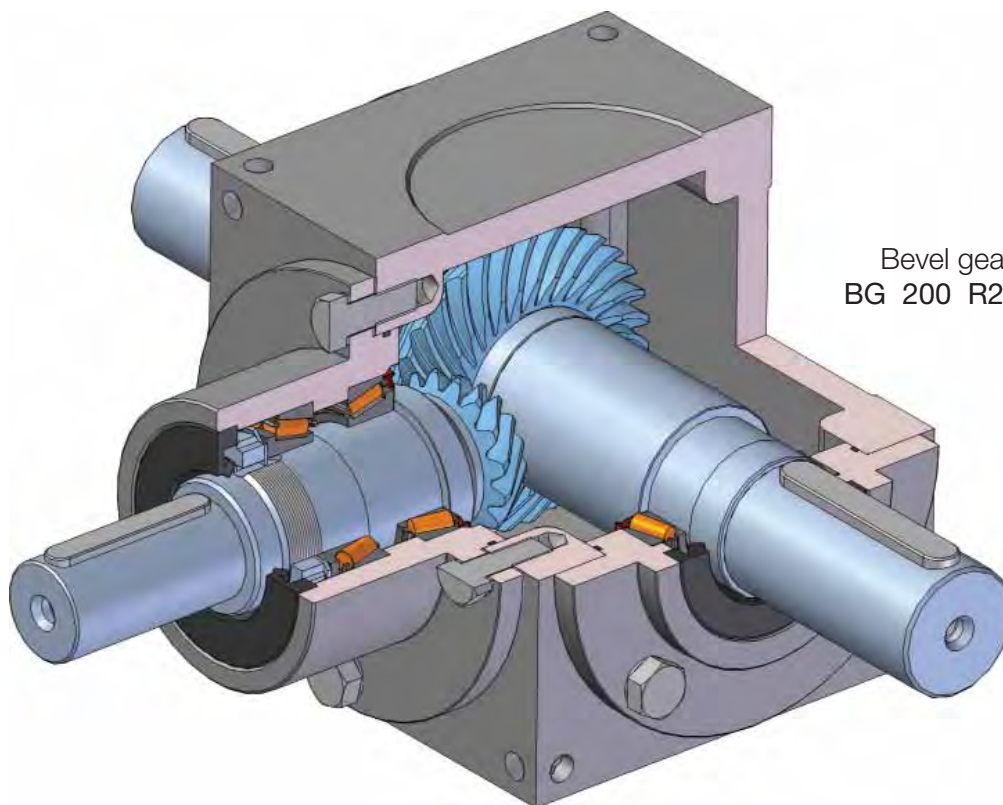

Bevel gearbox
BG 200 R2 S M2

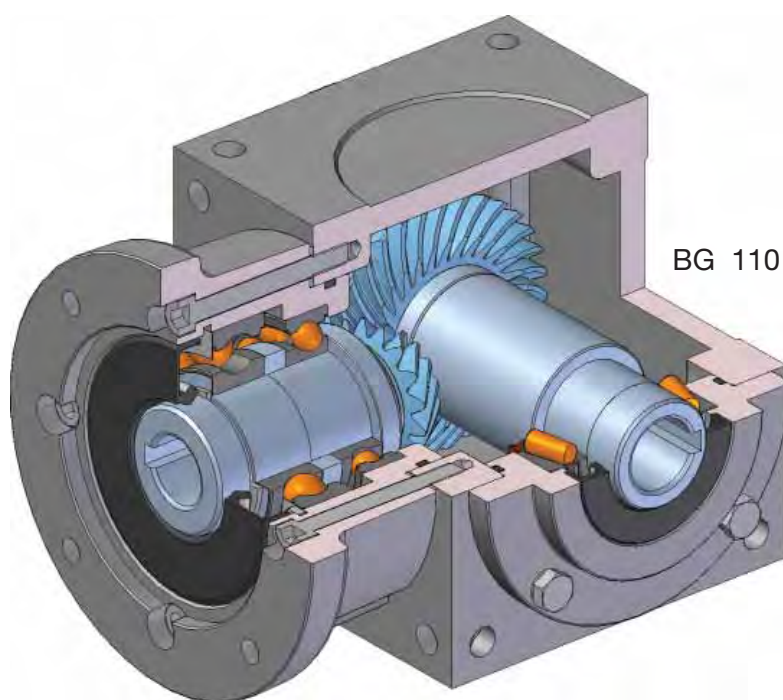

Bevel gearbox
BG 110 R2 MF (IEC 80 B14) H

Bevel gearboxes BG Series

Materials and components

Housing

- cubic shape
- material: grey cast iron EN-GJL-250 (UNI EN 1561)
- all 6 sides machine finished
- on request: stainless steel

Covers and hubs

- material: grey cast iron EN-GJL-250 (UNI EN 1561)
- machining: internal centring tolerance **h7**, outer centring tolerance **f7**
- on request: stainless steel

Solid shafts

- material: carbon steel C45E +H +QT (UNI EN 10083-2), hardened and tempered
- machining: cylindrical end, ground in tolerance **j6**, with key according to DIN 6885 Part 1
- on request: stainless steel
 - shaft end with spline profile according to DIN 5480
 - shaft end machined to drawing

Hollow shafts

- material: input hollow shaft - carbon steel C45E +H +QT (UNI EN 10083-2), hardened and tempered
output hollow shaft - alloy steel 39 NiCrMo 3 (UNI EN 10083-3), hardened and tempered
- machining: cylindrical end, ground in tolerance **H7**, with keyway according to DIN 6885 Part 1
- on request: stainless steel
 - bore with spline profile according to ISO 14

Bevel gears

- material: alloy steel 20 MnCr 5 (UNI EN 10084), case-hardened and tempered
- tothing: GLEASON, with spiroidal tooth
- running in with lapping in pairs

Seals

- oil seals in NBR, on request in VITON
- O-rings in NBR

Bearings

- taper roller bearings on solid output shaft and input shafts
- ball bearings on hollow input shaft for motor flange
- on request: larger bearings for higher radial and/or axial load capacity

Bevel gearbox selection

The selection of a bevel gearbox depends on several application factors:

- the kinematic scheme of the application to determine the design form, the kinematic scheme of the gear assembling and the shafts' rotation directions;
- torque and rotation speed required by the load (operating machine);
- load variability, regarding the operating machine and its inertia;
- working cycle: number of starts-up per hour, operating time in hours per day, duty cycle;
- environmental conditions, ambient temperature, presence of aggressive agents;
- service life requirements in terms of operating hours of the application;
- type of engine or type of drive on the bevel gearbox input, available or required by the application.

The above mentioned points are all very important to determine the right size and the type of suitable bevel gearbox for customer's application.

To simplify the selection, some factors, which take into consideration the variability of the above mentioned conditions, are introduced. Applying these factors on the performances required by the application, we obtain recalculated reference performances which should be considered as a starting base for the selection by consulting the table of **Nominal performances** given for each bevel gearbox size.

The nominal data required by the application or by the operating machine are:

- rotation speed , n [rpm]
- torque, M_m [Nm]

These data allow to calculate the **required nominal power** P_n [kW]:

$$P_n = \frac{M_m \times n}{9550}$$

It is then necessary to determine the **recalculated reference power** P , defined by the following formula:

$$P = P_n \times f_c \times f_u \times f_d$$

where:

- P_n [kW] - required nominal power
- f_c - load factor
- f_u - daily operating time factor
- f_d - service life factor

The **load factor** f_c regards the load variability and the number of starts-up per hour; for its quantification and explanation please refer to the description and the table below. The **load factor** f_c , regarding the load variability, is defined as follows:

- f_{c1} - light overloads: load variation not exceeding 10% of the required nominal load, no mass to be accelerated
- f_{c2} - medium overloads: load variation not exceeding 25% of the required nominal load, with mass to be accelerated
- f_{c3} - heavy overload: load variation up to 100% of the required nominal load, with large mass to be accelerated

Number of starts-up per hour	1	5	60	120	240	1000	1800
f_{c1}	1	1	1.1	1.2	1.25	1.3	1.4
f_{c2}	1.2	1.2	1.3	1.4	1.45	1.5	1.6
f_{c3}	1.5	1.5	1.6	1.7	1.75	1.8	2

Bevel gearboxes BG Series

The **daily operating factor** f_u considers the number of operating hours per day, referring to operating under load with duty cycle required by the application:

Operating hours / day	1	2	4	8	16	24
f_u	0.7	0.8	0.9	1	1.15	1.3

The **service life factor** f_d considers the life time required by the application compared to the life time calculated with performances shown in the tables (average value 10 000 hours), with reference to the gears.

Theoretic service life [hours]	20 000	15 000	10 000	5 000	3 000
f_d	1.2	1.1	1	0.9	0.8

With the **calculated input power** P

$$P = P_n \times f_c \times f_u \times f_d$$

it is possible to calculate the **torque M_{t2} required on the gearbox output**, considering the rotation speed required by the operating machine or the load:

$$M_{t2} = \frac{P \times 9550}{n_2}$$

Based on **Nominal performances** table on page 12 – 13, using M_{t2} and n_2 , it is possible to determine the bevel gearbox size for an initial selection.

Then, evaluating the gearbox ratios and the characteristics of the rotation speeds available or required by the application, it is possible to select easily a ratio and determine the bevel gearbox input speed. The **input power P_1 [kW] required on the bevel gearbox**, shown in the table, already takes into account the **total bevel gearbox efficiency** η , with the ratio and the considered input speed:

$$P_1 = \frac{M_{t2} \times n_2}{9550 \times \eta}$$

Usually, the ratio selection implies a modification of the real gearbox output speed regards to the previously calculated one, unless it is possible to vary and adjust the bevel gearbox input speed.

Bevel gearboxes BG Series

Thermal power limit (P_T)

After the gearbox size has been determined, it is necessary to verify the thermal operating conditions, which means to verify if the selected gearbox can operate in the required conditions without risk of overheating of the oil lubricant and of the components.

Each gearbox has a **thermal power limit** P_T , which is determined based on continuous operating duty cycle over max. 3 hours at 20°C environment temperature, value stated in the table at the bottom of this page, which must not be exceeded without a controlled and forced cooling.

In case of risk of exceeding the thermal power limit, the bevel gearboxes should be always lubricated exclusively with oil instead of grease.

In order to consider the real environment conditions, if different from 20°C, and the duty cycle, if different from the reference one (continuous operating over max. 3 hours), two factors are introduced which modify the thermal power limit, allowing the calculation of the **corrected thermal power limit** P_{Tc} :

$$P_{Tc} = P_T \times f_T \times f_i$$

where:

P_T - thermal power limit

f_T - ambient temperature factor

f_i - duty cycle factor referred to continuous operating over 3 hours (period of time considered to determine the thermal power limit)

Ambient temperature factor f_T :

T [°C]	0	10	20	30	40	50	60
f_T	1.3	1.15	1	0.85	0.7	0.55	0.5

Duty cycle factor f_i :

Operating time over 3 hours [%]	100	80	60	40	20	10
f_i	1	1.2	1.3	1.5	1.6	1.8

Therefore, the continuous power used over 3 hours in the selected bevel gearbox must not exceed the value of the **corrected thermal power** P_{Tc} referred to the same gearbox, otherwise the oil lubricant should be cooled.

Thermal power limit (P_T) for continuous operating over 3 hours at 20°C ambient temperature:

SIZE	86	110	134	166	200	250
P_T [kW]	3.4	5.5	8	12.2	17.9	26.5

Bevel gearboxes BG Series

Design

	<p>input: solid shaft, cylindrical with key, STANDARD diameter (designation: S)</p> <p>output: solid shaft, cylindrical with key on one of the two sides (designation: M1)</p>	BG • • S M1
	<p>input: solid shaft, cylindrical with key, LARGE diameter (designation: R)</p> <p>output: solid shaft, cylindrical with key on one of the two sides (designation: M1)</p>	BG • • R M1
	<p>input: solid shaft, cylindrical with key, STANDARD diameter (designation: S)</p> <p>output: solid shaft, cylindrical with key on both sides (designation: M2)</p>	BG • • S M2
	<p>input: solid shaft, cylindrical with key, LARGE diameter (designation: R)</p> <p>output: solid shaft, cylindrical with key on both sides (designation: M2)</p>	BG • • R M2
	<p>input: solid shaft, cylindrical with key, STANDARD diameter (designation: S)</p> <p>output: hollow shaft, cylindrical hole with keyway (designation: H)</p>	BG • • S H
	<p>input: solid shaft, cylindrical with key, STANDARD diameter (designation: S)</p> <p>output: solid shaft with hub, cylindrical with key on one of the two sides STANDARD diameter (designation: S1)</p>	BG • • S S1
	<p>input: solid shaft, cylindrical with key, STANDARD diameter (designation: S)</p> <p>output: solid shaft with hub, cylindrical with key on one of the two sides LARGE diameter (designation: R1)</p>	BG • • S R1
	<p>input: solid shaft, cylindrical with key, LARGE diameter (designation: R)</p> <p>output: solid shaft with hub, cylindrical with key on one of the two sides LARGE diameter (designation: R1)</p>	BG • • R R1
	<p>input: solid shaft, cylindrical with key, STANDARD diameter (designation: S)</p> <p>output: two solid shafts with hub, cylindrical with key with opposite rotation direction STANDARD diameter (designation: S2)</p>	BG • • S S2
	<p>input: solid shaft, cylindrical with key, STANDARD diameter (designation: S)</p> <p>output: two solid shafts with hub, cylindrical with key with opposite rotation direction LARGE diameter (designation: R2)</p>	BG • • S R2
	<p>input: solid shaft, cylindrical with key, LARGE diameter (designation: R)</p> <p>output: two solid shafts with hub, cylindrical with key with opposite rotation direction LARGE diameter (designation: R2)</p>	BG • • R R2

Bevel gearboxes BG Series

Design



input: IEC motor flange and hollow shaft with cylindrical hole and keyway (designation: MF)

output: solid shaft, cylindrical with key on one of the two sides (designation: M1)

BG • • MF M1

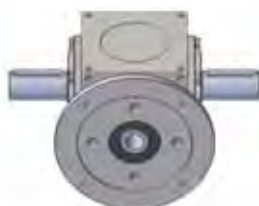

input: IEC motor flange and hollow shaft with cylindrical hole and keyway (designation: MF)

output: solid shaft, cylindrical with key on both sides (designation: M2)

BG • • MF M2



input: IEC motor flange and hollow shaft with cylindrical hole and keyway (designation: MF)

output: hollow shaft, cylindrical hole with keyway (designation: H)

BG • • MF H



input: IEC motor flange and hollow shaft with cylindrical hole and keyway (designation: MF)

output: solid shaft with hub, cylindrical with key on one of the two sides STANDARD diameter (designation: S1)

BG • • MF S1



input: IEC motor flange and hollow shaft with cylindrical hole and keyway (designation: MF)

output: solid shaft with hub, cylindrical with key on one of the two sides LARGE diameter (designation: R1)

BG • • MF R1

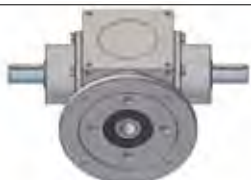

input: IEC motor flange and hollow shaft with cylindrical hole and keyway (designation: MF)

output: two solid shafts with hub, cylindrical with key with opposite rotation direction STANDARD diameter (designation: S2)

BG • • MF S2



input: IEC motor flange and hollow shaft with cylindrical hole and keyway (designation: MF)

output: two solid shafts with hub, cylindrical with key with opposite rotation direction LARGE diameter (designation: R2)

BG • • MF R2

Bevel gearboxes BG Series

Technical features summary

SIZE	BG 86	BG 110	BG 134
Housing side dimensions [mm]	86	110	134
Ratio	1 : 1 1 : 1.5 1 : 2 1 : 3 1 : 4		
Total efficiency (η)	0.90 \leq η \leq 0.93 (*)		
Input: solid shaft, cylindrical with key, STANDARD diameter [mm]	\varnothing 16 j6	\varnothing 20 j6	\varnothing 24 j6
Input: solid shaft, cylindrical with key, LARGER diameter [mm]	\varnothing 24 j6	\varnothing 26 j6	\varnothing 32 j6
Input: IEC motor flange	IEC 71 B5 IEC 80 B5 IEC 80 B14	IEC 80 B5 IEC 80 B14 IEC 90 B5 IEC 90 B14	IEC 90 B5 IEC 100-112 B5 IEC 100-112 B14
Output: solid shaft, cylindrical with key	\varnothing 24 j6	\varnothing 26 j6	\varnothing 32 j6
Output: hollow shaft with cylindrical hole and keyway	\varnothing 16 H7	\varnothing 20 H7	\varnothing 24 H7
Output: solid shaft with hub, cylindrical with key, STANDARD diameter [mm]	\varnothing 16 j6	\varnothing 20 j6	\varnothing 24 j6
Output: solid shaft with hub, cylindrical with key, LARGE diameter [mm]	\varnothing 24 j6	\varnothing 26 j6	\varnothing 32 j6
Gearbox housing, shaft hub and covers material	grey cast iron EN-GJL-250 (UNI EN 1561)		
Solid input shaft material	steel C45E +H +QT (UNI EN 10083-2), hardened and tempered		
Hollow input shaft material	steel C45E +H +QT (UNI EN 10083-2), hardened and tempered		
Solid output shaft material	steel C45E +H +QT (UNI EN 10083-2), hardened and tempered		
Hollow output shaft material	steel 39 NiCrMo 3 (UNI EN 10083-3), hardened and tempered		
Bevel gears	toothings: spiral GLEASON material: steel 20 MnCr 5 (UNI EN 10084), case-hardened lapped in pairs		
Input - solid shaft: bearings	2 \times 6005	2 \times 32006	2 \times 32007
Input - flange and hollow shaft for IEC motor: bearings	6005 + 6205	6007 + 6207	6008 + 6208
Main output – solid or hollow shaft: bearings	2 \times 6005	2 \times 32006	2 \times 32007
Additional output – solid shaft with hub: bearings	2 \times 6005	2 \times 32006	2 \times 32007
Gearbox mass [kg] (gearbox with solid input shaft and solid output shaft on both sides)	3.5	9	18

* value referred to bevel gearboxes without additional output

Bevel gearboxes BG Series

Technical features summary

BG 166	BG 200	BG 250	SIZE		
166	200	250	Housing side dimensions [mm]		
1 : 1	1 : 1.5	1 : 2	1 : 3	1 : 4	Ratio
$0.90 \leq \eta \leq 0.93$ (*)					Total efficiency (η)
$\varnothing 32$ j6	$\varnothing 42$ j6	$\varnothing 55$ j6	Input: solid shaft, cylindrical with key, STANDARD diameter [mm]		
$\varnothing 45$ j6	$\varnothing 55$ j6	$\varnothing 70$ j6	Input: solid shaft, cylindrical with key, LARGER diameter [mm]		
90 B5 100-112 B5 100-112 B14	100-112 B5 132 B5 132 B14	132 B5 160 B5	Input: IEC motor flange		
$\varnothing 45$ j6	$\varnothing 55$ j6	$\varnothing 70$ j6	Output: solid shaft, cylindrical with key		
$\varnothing 32$ H7	$\varnothing 42$ H7	$\varnothing 55$ H7	Output: hollow shaft with cylindrical hole and keyway		
$\varnothing 32$ j6	$\varnothing 42$ j6	$\varnothing 55$ j6	Output: solid shaft with hub, cylindrical with key, STANDARD diameter [mm]		
$\varnothing 45$ j6	$\varnothing 55$ j6	$\varnothing 70$ j6	Output: solid shaft with hub, cylindrical with key, LARGE diameter [mm]		
grey cast iron EN-GJL-250 (UNI EN 1561)			Gearbox housing, shaft hub and covers material		
steel C45E +H +QT (UNI EN 10083-2), hardened and tempered			Solid input shaft material		
steel C45E +H +QT (UNI EN 10083-2), hardened and tempered			Hollow input shaft material		
steel C45E +H +QT (UNI EN 10083-2), hardened and tempered			Solid output shaft material		
steel 39 NiCrMo 3 (UNI EN 10083-3), hardened and tempered			Hollow output shaft material		
toothings: spiral GLEASON material: steel 20 MnCr 5 (UNI EN 10084), case-hardened lapped in pairs			Bevel gears		
2 × 32010	2 × 32012	2 × 32016	Input - solid shaft: bearings		
2 × 32010	2 × 32012	2 × 32016	Input - flange and hollow shaft for IEC motor: bearings		
2 × 32010	2 × 32012	2 × 30215	Main output – solid or hollow shaft: bearings		
2 × 32010	2 × 32012	2 × 32016	Additional output – solid shaft with hub: bearings		
32	60	145	Gearbox mass [kg] (gearbox with solid input shaft and solid output shafts on both sides)		

* value referred to bevel gearboxes without additional output

Bevel gearboxes BG Series

Nominal performances – torque and power

SIZE		BG 86		BG 110		BG 134	
n_1 rpm	n_2 rpm	P_{1max} [kW]	T_{2max} [Nm]	P_{1max} [kW]	T_{2max} [Nm]	P_{1max} [kW]	T_{2max} [Nm]
Ratio R 1							
50	50	0.32	60	0.97	180	1.62	300
250	250	0.94	35	3.78	140	7.85	291
500	500	1.62	30	6.21	115	13.0	241
1000	1000	2.7	25	10.3	95	21.1	196
1500	1500	3.24	20	13.0	80	28.1	173
2000	2000	3.89	18	16.2	75	34.3	159
3000	3000	5.18	16	22.7	70	45.6	141
Ratio R 1.5							
50	33	0.23	65	0.49	135	0.81	225
250	167	0.72	40	2.25	125	3.95	220
500	333	1.08	30	4.32	120	7.75	215
1000	667	1.80	25	6.84	95	14.7	204
1500	1000	2.48	23	9.18	85	20.6	191
2000	1333	2.88	20	11.5	80	25.2	175
3000	2000	3.89	18	15.1	70	33.4	155
Ratio R 2							
50	25	0.15	55	0.31	115	0.51	190
250	125	0.54	40	1.42	105	2.44	181
500	250	0.94	35	2.70	100	4.71	175
1000	500	1.62	30	5.13	95	9.02	167
1500	750	2.02	25	7.29	90	13.0	160
2000	1000	2.38	22	9.18	85	16.7	155
3000	1500	3.24	20	12.1	75	23.4	144
Ratio R 3							
50	17	0.06	35	0.14	80	0.23	126
250	83	0.29	32	0.63	70	1.07	119
500	167	0.54	30	1.17	65	2.04	113
1000	333	1.01	28	2.19	61	3.91	109
1500	500	1.40	26	3.16	59	5.66	105
2000	667	1.58	22	4.07	57	7.30	101
3000	1000	2.16	20	5.94	55	10.3	95
Ratio R 4							
50	12.5	0.04	30	0.09	65	0.14	104
250	62.5	0.18	26	0.37	55	0.59	84
500	125	0.34	25	0.67	50	1.11	82
1000	250	0.65	24	1.21	45	2.12	79
1500	375	0.93	23	1.75	43	3.08	76
2000	500	1.19	22	2.26	42	3.98	74
3000	750	1.62	20	3.24	40	5.63	70
Thermal power limit [kW]		3.4		5.5		8	

The torque and power values stated in the **Nominal performances** table refer to a minimum service life of 10 000 hours at following operating conditions:

- applied load: uniform and without variations
- driving unit: electric motor
- rotation direction: one-way
- 1 (one) start-up per hour
- operating hours per day: 8
- ambient temperature: 20°C
- thermal power limit value calculated considering a continuous operating time over 3 hours at nominal performances

Bevel gearboxes BG Series

Nominal performances – torque and power

BG 166		BG 200		BG 250		SIZE	
P_{1max} [kW]	T_{2max} [Nm]	P_{1max} [kW]	T_{2max} [Nm]	P_{1max} [kW]	T_{2max} [Nm]	n_2 [rpm]	n_1 [rpm]
Ratio R 1							
3.02	560	5.24	970	10.7	1980	50	50
11.4	420	22.1	820	37.2	1380	250	250
18.4	340	36.2	670	60.5	1120	500	500
30.2	280	59.4	550	98.2	910	1000	1000
40.5	250	77.7	480	131	810	1500	1500
50.0	230	95.0	440	160	740	2000	2000
64.8	200	126	390	214	660	3000	3000
Ratio R 1.5							
1.51	420	2.63	730	5.33	1480	33	50
7.38	410	13.0	720	26.1	1450	167	250
13.3	370	24.8	690	45.3	1260	333	500
21.6	300	43.2	600	73.4	1020	667	1000
29.2	270	57.2	530	98.2	910	1000	1500
36.0	250	70.5	490	119	830	1333	2000
47.5	220	92.8	430	160	740	2000	3000
Ratio R 2							
0.97	360	1.67	620	3.45	1280	25	50
4.72	350	8.23	610	17.0	1260	125	250
9.18	340	16.2	600	33.2	1230	250	500
17.3	320	30.8	570	57.8	1070	500	1000
22.7	280	44.5	550	76.9	950	750	1500
28.1	260	55.1	510	93.9	870	1000	2000
37.3	230	72.9	450	125	770	1500	3000
Ratio R 3							
0.43	240	0.76	420	1.53	850	17	50
2.07	230	3.60	400	7.42	825	83	250
3.96	220	7.02	390	14.6	810	167	500
7.56	210	13.3	370	28.1	780	333	1000
10.8	200	19.4	360	40.5	750	500	1500
14.0	195	25.2	350	52.5	730	667	2000
20.0	185	35.6	330	74.5	690	1000	3000
Ratio R 4							
0.27	200	0.46	340	0.94	700	12.5	50
1.15	170	1.96	290	4.18	620	62.5	250
2.16	160	3.78	280	8.10	600	125	500
4.18	155	7.29	270	15.7	580	250	1000
6.07	150	10.5	260	22.7	560	375	1500
7.83	145	13.5	250	29.1	540	500	2000
11.4	140	19.4	30.8	42.1	520	750	3000
12.2		17.9		26.5		Thermal power limit [kW]	

n_1 - input shaft speed
 n_2 - output shaft speed
 P_{1max} - max. input power
 T_{2max} - max. output torque

Bevel gearboxes BG Series

Identification of bevel gearbox housing sides

To describe and define a bevel gearbox accurately, to indicate the mounting side of the bevel gear on the external structure or to determine the side of the oil plugs and air breather, it is necessary to identify each side of the gearbox housing.

In the following scheme, each side of the gearbox housing is identified with a letter and a colour. These references are used hereafter to show the direction of shafts rotation and the mounting – operating position of the bevel gearbox.

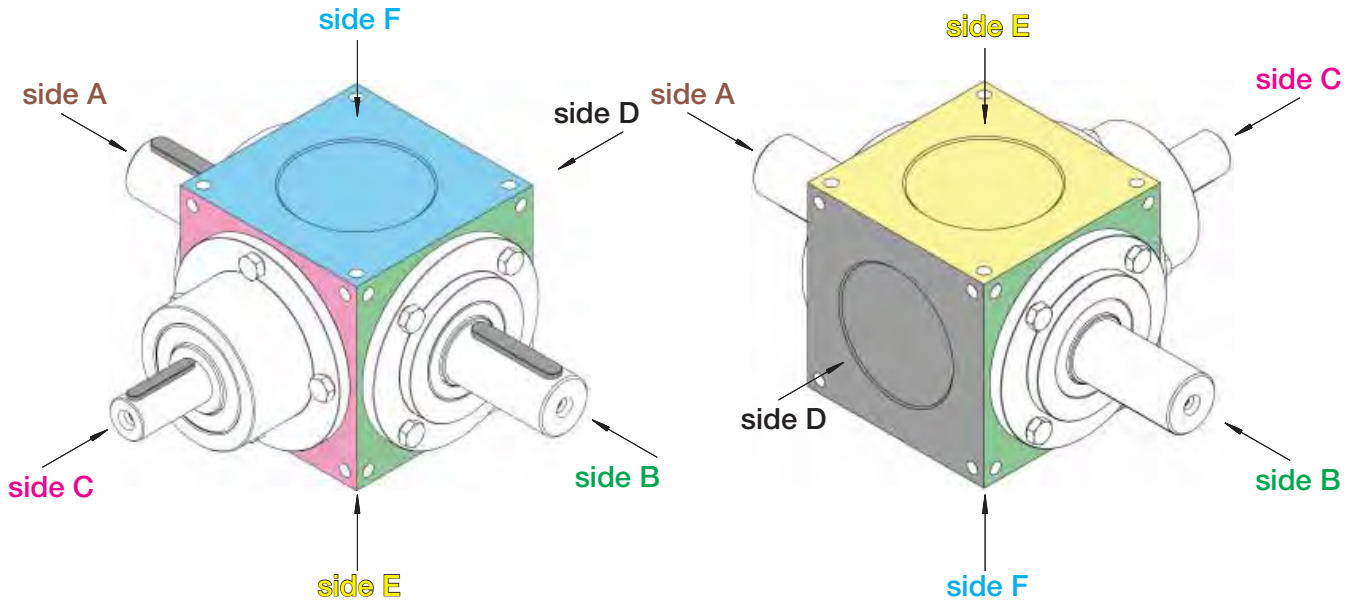

Side C is the side of the main input (solid shaft or IEC motor flange).

Side A and **side B** correspond to the **main output** axis of the gearbox (solid shaft, cylindrical with key, on one or both sides, or hollow shaft with cylindrical hole and keyway).

On **side D** and/or **side E** and/or **side F** it is possible to mount a solid shaft with hub, cylindrical with key, as **additional output**.

Bevel gearbox input: type and designation

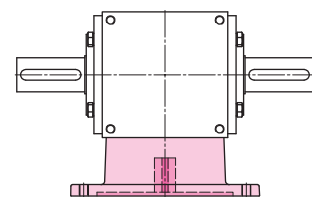
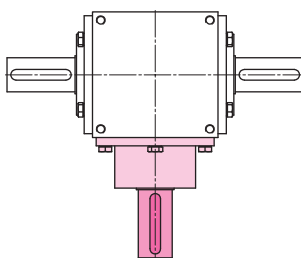
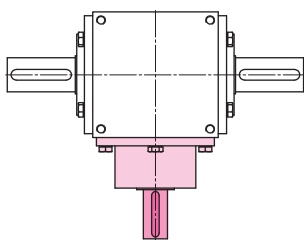

Solid shaft, cylindrical with key,
STANDARD diameter
Designation: S

Solid shaft, cylindrical with key,
LARGE diameter
Designation: R

IEC motor flange and hollow shaft
with cylindrical hole and keyway
Designation: MF

Bevel gearboxes BG Series

Bevel gearbox main output: type and designation

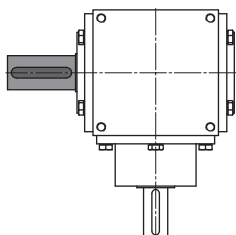

Solid shaft, one output
Designation: M1

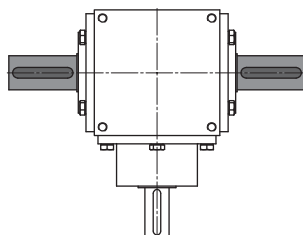

Solid shaft, double output
Designation: M2

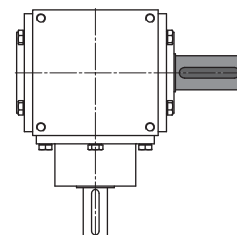

Solid shaft, one output
Designation: M1

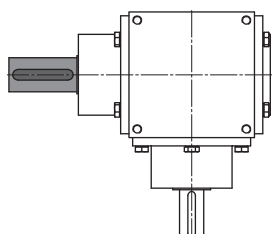

One solid shaft with hub

Diameter: STANDARD
Designation: S1
Diameter: LARGE
Designation: R1

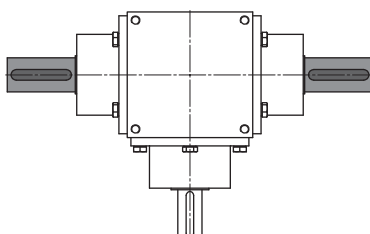

Two solid shafts with hub
with opposite rotation direction
Diameter: STANDARD
Designation: S2
Diameter: LARGE
Designation: R2

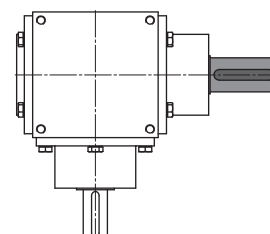

One solid shaft with hub

Diameter: STANDARD
Designation: S1
Diameter: LARGE
Designation: R1

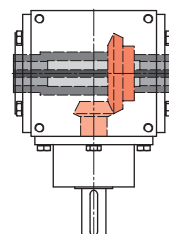
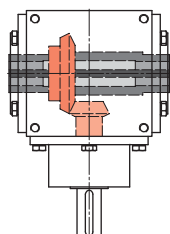

Hollow shaft:
cylindrical hole and keyway
Designation: H

Bevel gearbox additional output: type, designation and position

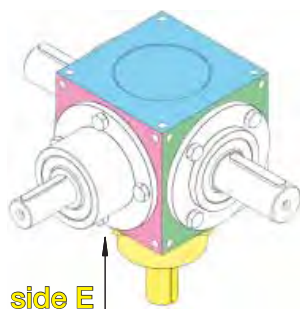

side E

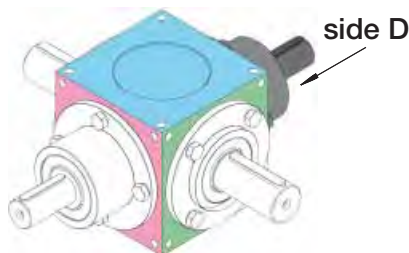

side D

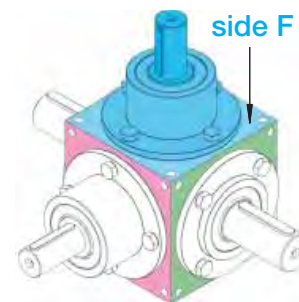

side F

Solid shaft with hub, cylindrical with key		
Diameter: STANDARD	Diameter: LARGE	
Designation: S	Designation: R	
Position: E	Position: D	Position: F

Bevel gearboxes BG Series

Overall dimensions: BG •• S M2

input: solid shaft, STANDARD diameter

output: solid shaft on both sides

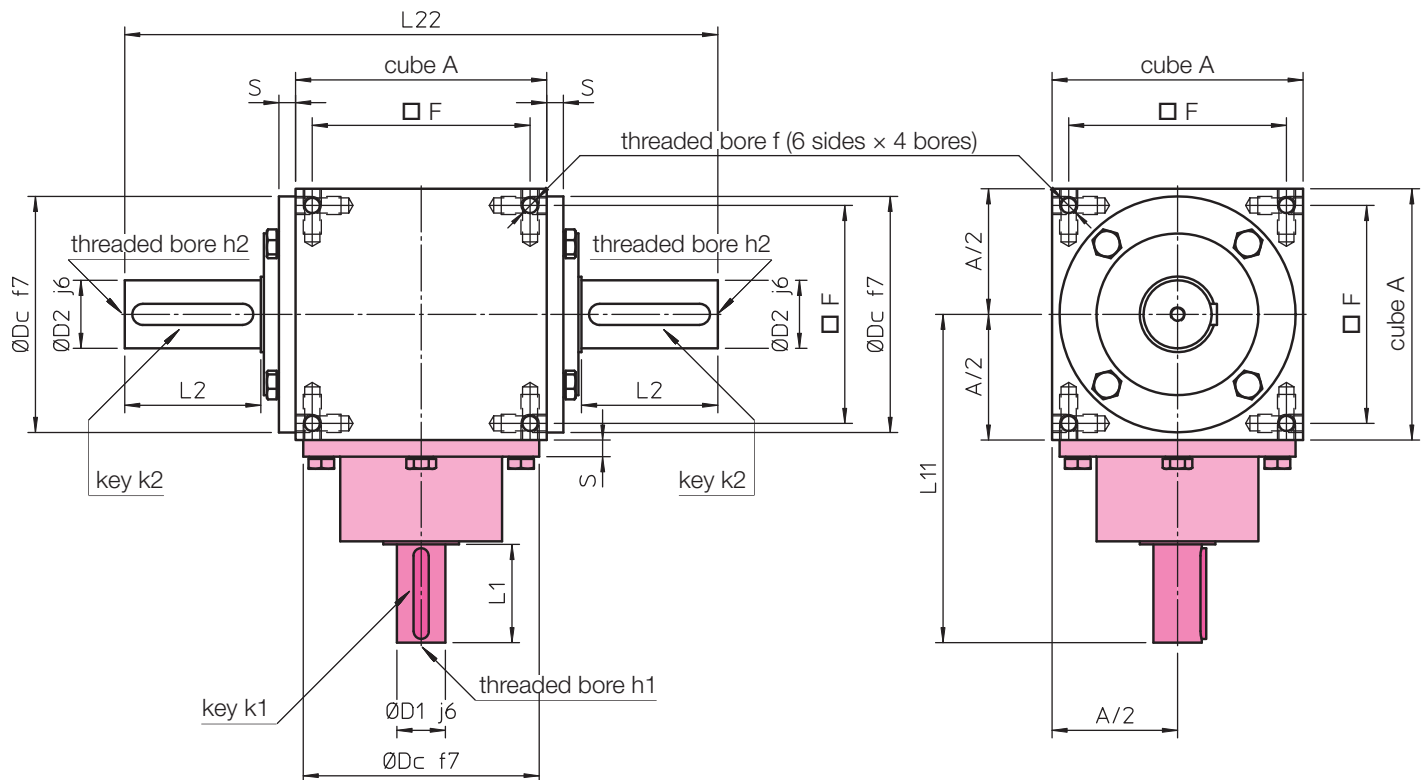

scheme: 10

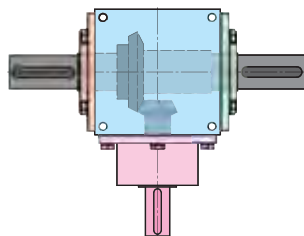

scheme: 20

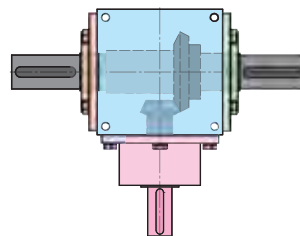

SIZE	BG 86	BG 110	BG 134	BG 166	BG 200	BG 250
cube A	86 × 86 × 86	110 × 110 × 110	134 × 134 × 134	166 × 166 × 166	200 × 200 × 200	250 × 250 × 250
Ø D1	16	20	24	32	42	55
Ø D2	24	26	32	45	55	70
Ø Dc	84	100	122	156	185	230
□ F	70 × 70	90 × 90	114 × 114	144 × 144	174 × 174	216 × 216
L1	30	40	50	65	85	100
L11	114	150	182	217	267	318
L2	50	55	65	90	110	140
L22	220	254	304	392	470	580
S	10	8	9	11	11	11
f	M8, depth 20	M10, depth 25	M10, depth 25	M12, depth 30	M14, depth 35	M16, depth 40
h1	M6, depth 12	M8, depth 20	M8, depth 20	M10, depth 25	M10, depth 25	M12, depth 25
h2	M6, depth 12	M8, depth 20	M8, depth 20	M10, depth 25	M10, depth 25	M12, depth 25
k1	5 × 5 × 25	6 × 6 × 35	8 × 7 × 45	10 × 8 × 60	12 × 8 × 80	16 × 10 × 90
k2	8 × 7 × 40	8 × 7 × 45	10 × 8 × 55	14 × 9 × 80	16 × 10 × 100	20 × 12 × 120

Bevel gearboxes BG Series

Overall dimensions: BG • • R M2

input: solid shaft, LARGE diameter

output: solid shaft on both sides

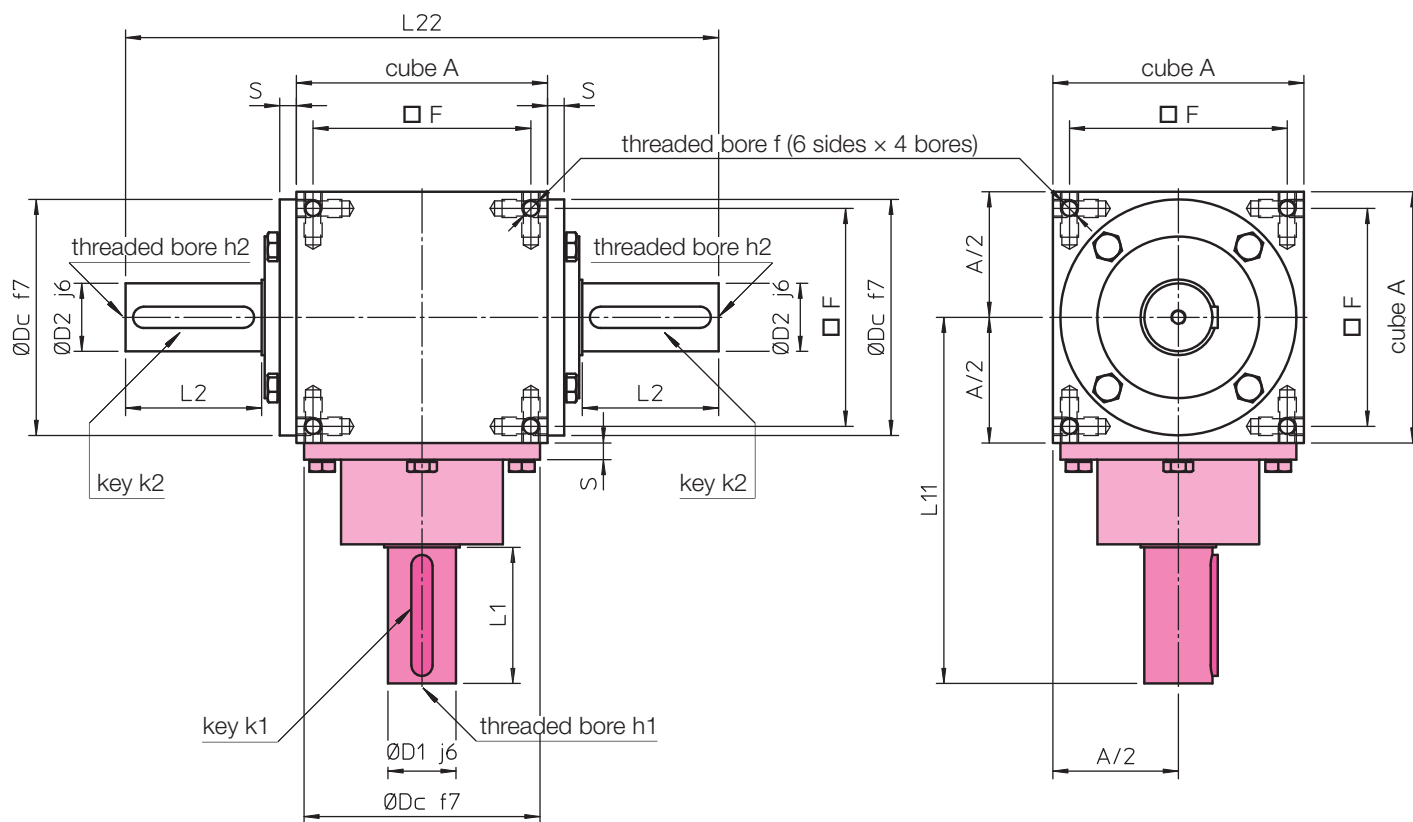

scheme: 10

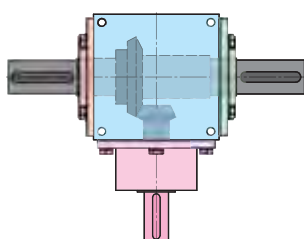

scheme: 20

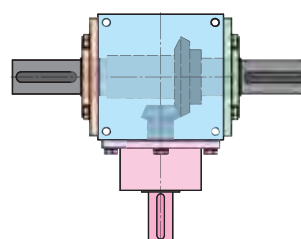

SIZE	BG 86	BG 110	BG 134	BG 166	BG 200	BG 250
cube A	86 × 86 × 86	110 × 110 × 110	134 × 134 × 134	166 × 166 × 166	200 × 200 × 200	250 × 250 × 250
Ø D1	24	26	32	45	55	70
Ø D2	24	26	32	45	55	70
Ø Dc	84	100	122	156	185	230
□ F	70 × 70	90 × 90	114 × 114	144 × 144	174 × 174	216 × 216
L1	50	55	65	90	110	140
L11	134	165	197	242	292	358
L2	50	55	65	90	110	140
L22	220	254	304	392	470	580
S	10	8	9	11	11	11
f	M8, depth 20	M10, depth 25	M10, depth 25	M12, depth 30	M14, depth 35	M16, depth 40
h1	M6, depth 12	M8, depth 20	M8, depth 20	M10, depth 25	M10, depth 25	M12, depth 25
h2	M6, depth 12	M8, depth 20	M8, depth 20	M10, depth 25	M10, depth 25	M12, depth 25
k1	8 × 7 × 40	8 × 7 × 45	10 × 8 × 55	14 × 9 × 80	16 × 10 × 100	20 × 12 × 120
k2	8 × 7 × 40	8 × 7 × 45	10 × 8 × 55	14 × 9 × 80	16 × 10 × 100	20 × 12 × 120

Bevel gearboxes BG Series

Overall dimensions: BG • • S M1

input: solid shaft, STANDARD diameter

output: solid shaft on one side

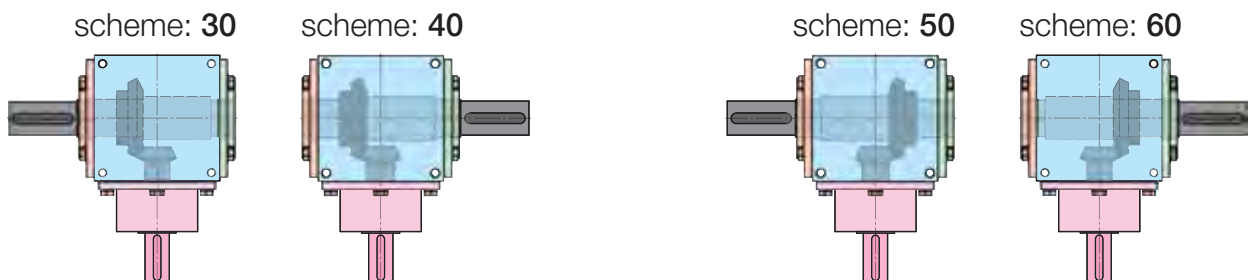
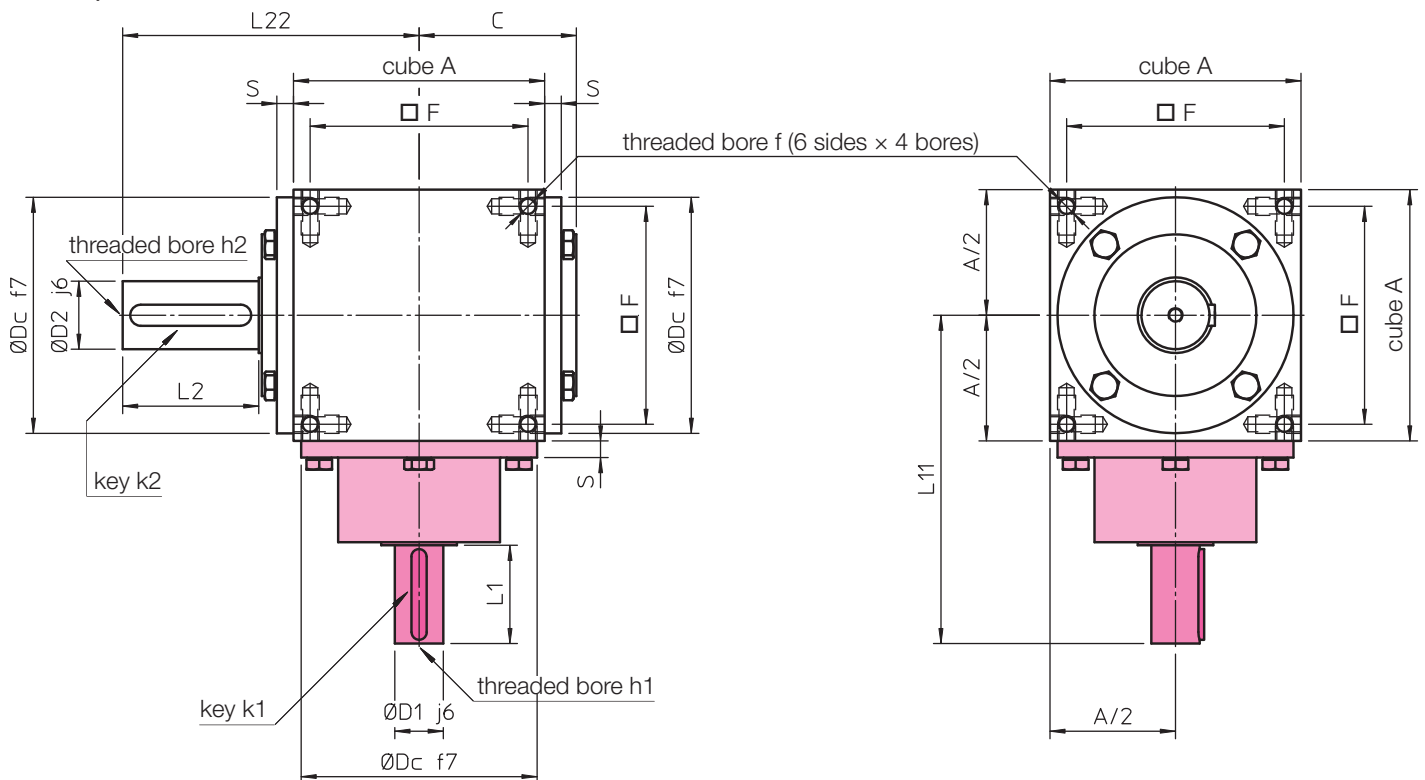

SIZE	BG 86	BG 110	BG 134	BG 166	BG 200	BG 250
cube A	86 × 86 × 86	110 × 110 × 110	134 × 134 × 134	166 × 166 × 166	200 × 200 × 200	250 × 250 × 250
C	58	70	75	104	123	145
Ø D1	16	20	24	32	42	55
Ø D2	24	26	32	45	55	70
Ø Dc	84	100	122	156	185	230
□ F	70 × 70	90 × 90	114 × 114	144 × 144	174 × 174	216 × 216
L1	30	40	50	65	85	100
L11	114	150	182	217	267	318
L2	50	55	65	90	110	140
L22	110	127	152	196	235	290
S	10	8	9	11	11	11
f	M8, depth 20	M10, depth 25	M10, depth 25	M12, depth 30	M14, depth 35	M16, depth 40
h1	M6, depth 12	M8, depth 20	M8, depth 20	M10, depth 25	M10, depth 25	M12, depth 25
h2	M6, depth 12	M8, depth 20	M8, depth 20	M10, depth 25	M10, depth 25	M12, depth 25
k1	5 × 5 × 25	6 × 6 × 35	8 × 7 × 45	10 × 8 × 60	12 × 8 × 80	16 × 10 × 90
k2	8 × 7 × 40	8 × 7 × 45	10 × 8 × 55	14 × 9 × 80	16 × 10 × 100	20 × 12 × 120

Bevel gearboxes BG Series

Overall dimensions: BG • • R M1

input: solid shaft, LARGE diameter

output: solid shaft on one side

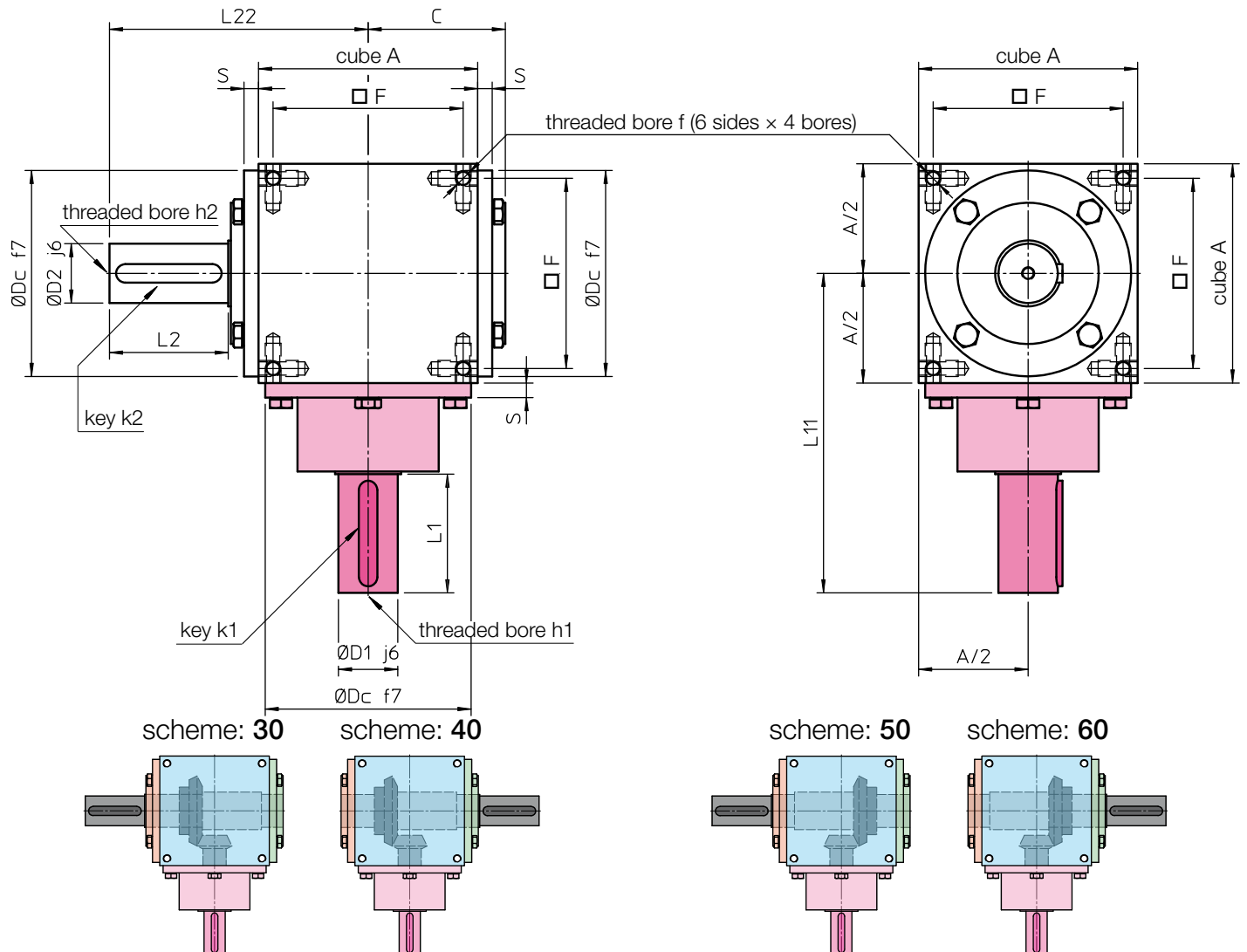

SIZE	BG 86	BG 110	BG 134	BG 166	BG 200	BG 250
cube A	86 × 86 × 86	110 × 110 × 110	134 × 134 × 134	166 × 166 × 166	200 × 200 × 200	250 × 250 × 250
C	58	70	75	104	123	145
Ø D1	24	26	32	45	55	70
Ø D2	24	26	32	45	55	70
Ø Dc	84	100	122	156	185	230
□ F	70 × 70	90 × 90	114 × 114	144 × 144	174 × 174	216 × 216
L1	50	55	65	90	110	140
L11	134	165	197	242	292	358
L2	50	55	65	90	110	140
L22	110	127	152	196	235	290
S	10	8	9	11	11	11
f	M8, depth 20	M10, depth 25	M10, depth 25	M12, depth 30	M14, depth 35	M16, depth 40
h1	M6, depth 12	M8, depth 20	M8, depth 20	M10, depth 25	M10, depth 25	M12, depth 25
h2	M6, depth 12	M8, depth 20	M8, depth 20	M10, depth 25	M10, depth 25	M12, depth 25
k1	8 × 7 × 40	8 × 7 × 45	10 × 8 × 55	14 × 9 × 80	16 × 10 × 100	20 × 12 × 120
k2	8 × 7 × 40	8 × 7 × 45	10 × 8 × 55	14 × 9 × 80	16 × 10 × 100	20 × 12 × 120

Bevel gearboxes BG Series

Overall dimensions: BG • • S S1

input: solid shaft, STANDARD diameter

output: solid shaft with hub, STANDARD diameter

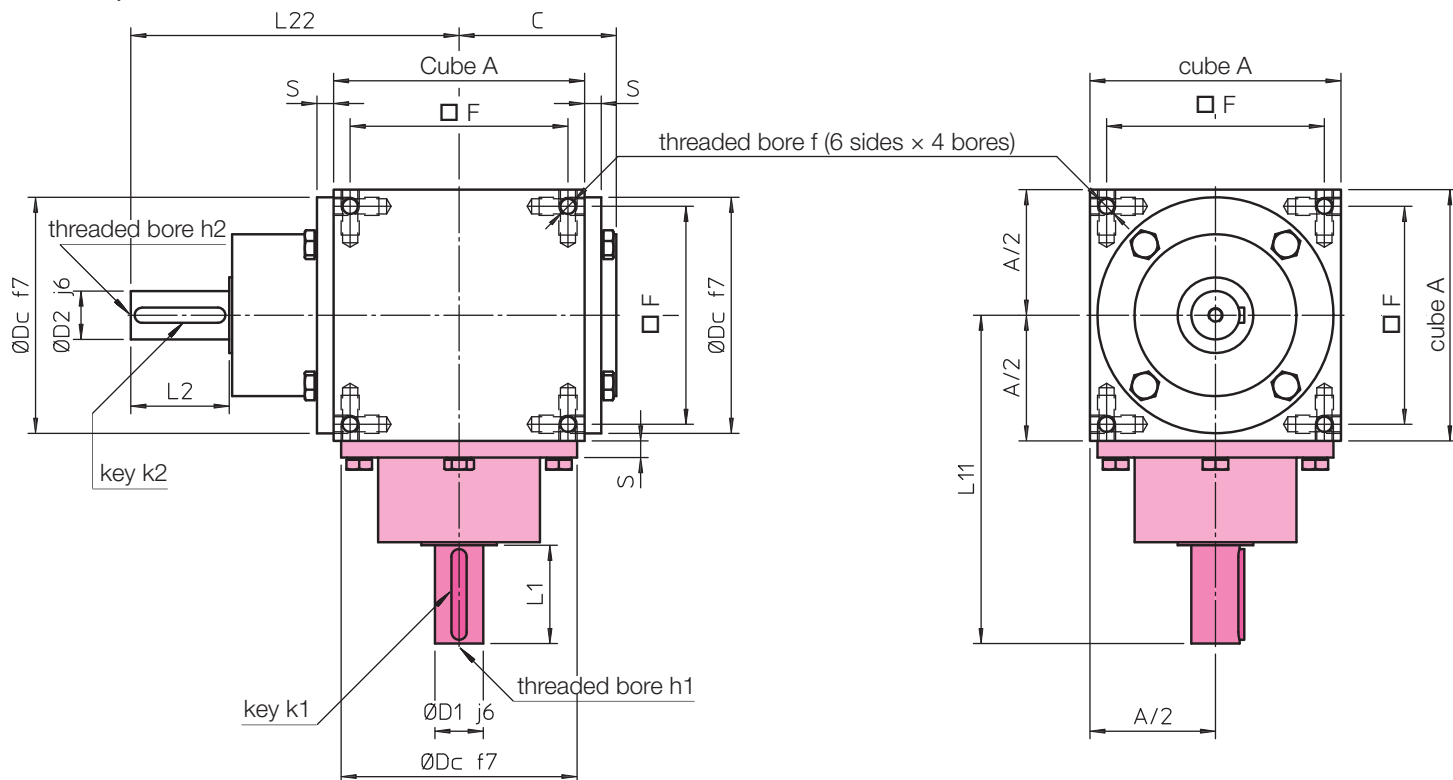

scheme: 70

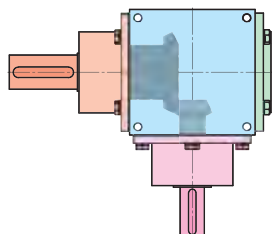

scheme: 90

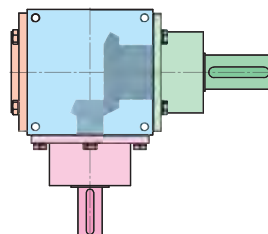

SIZE	BG 86	BG 110	BG 134	BG 166	BG 200	BG 250
cube A	86 × 86 × 86	110 × 110 × 110	134 × 134 × 134	166 × 166 × 166	200 × 200 × 200	250 × 250 × 250
C	58	70	75	104	123	145
Ø D1	16	20	24	32	42	55
Ø D2	16	20	24	32	42	55
Ø Dc	84	100	122	156	185	230
□ F	70 × 70	90 × 90	114 × 114	144 × 144	174 × 174	216 × 216
L1	30	40	50	65	85	100
L11	114	150	182	217	267	318
L2	30	40	50	65	85	100
L22	114	150	182	217	267	318
S	10	8	9	11	11	11
f	M8, depth 20	M10, depth 25	M10, depth 25	M12, depth 30	M14, depth 35	M16, depth 40
h1	M6, depth 12	M8, depth 20	M8, depth 20	M10, depth 25	M10, depth 25	M12, depth 25
h2	M6, depth 12	M8, depth 20	M8, depth 20	M10, depth 25	M10, depth 25	M12, depth 25
k1	5 × 5 × 25	6 × 6 × 35	8 × 7 × 45	10 × 8 × 60	12 × 8 × 80	16 × 10 × 90
k2	5 × 5 × 25	6 × 6 × 35	8 × 7 × 45	10 × 8 × 60	12 × 8 × 80	16 × 10 × 90

Bevel gearboxes BG Series

Overall dimensions: BG .. R R1

input: solid shaft, LARGE diameter

output: solid shaft with hub, LARGE diameter

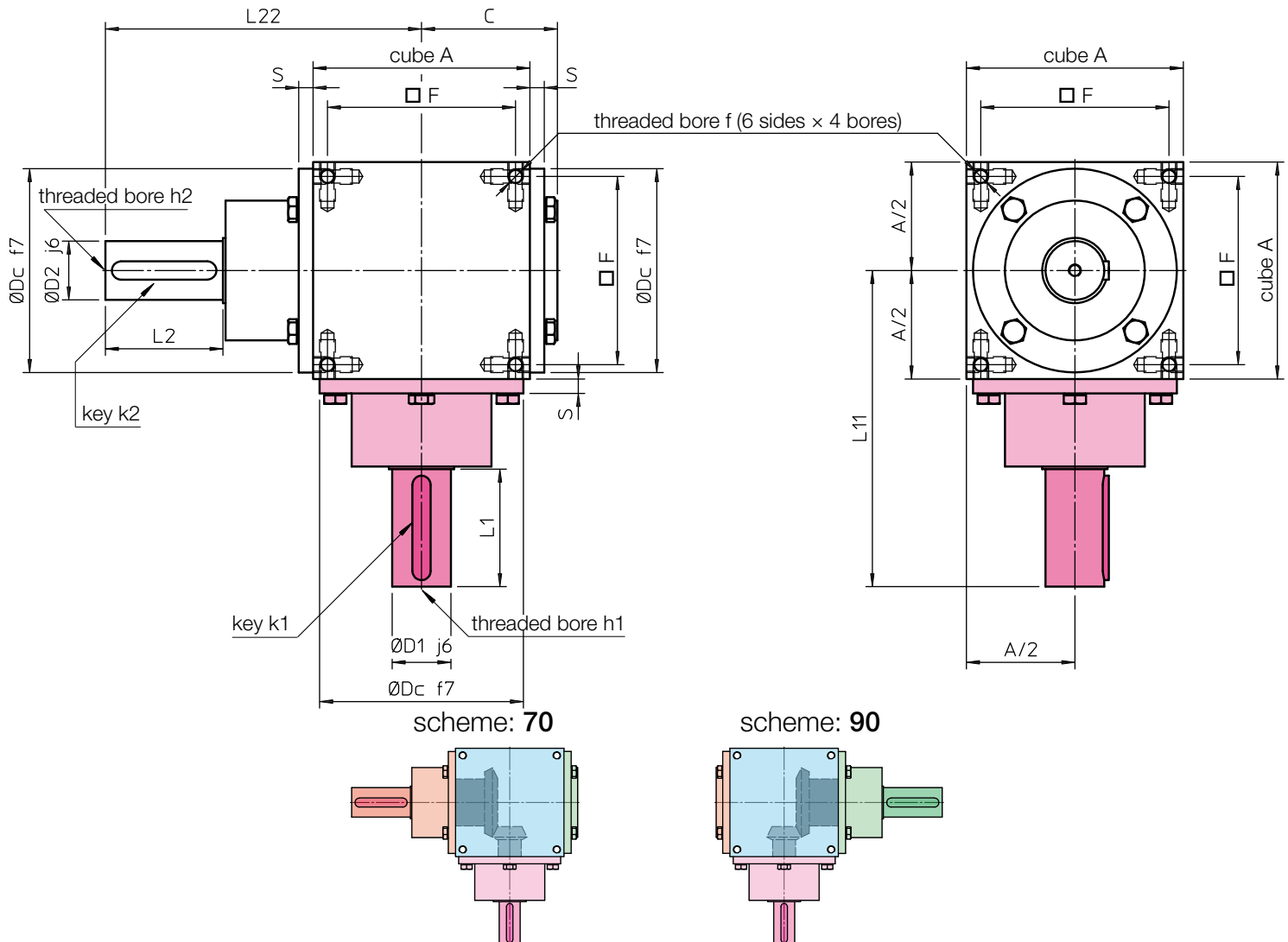

SIZE	BG 86	BG 110	BG 134	BG 166	BG 200	BG 250
cube A	86 × 86 × 86	110 × 110 × 110	134 × 134 × 134	166 × 166 × 166	200 × 200 × 200	250 × 250 × 250
C	58	70	75	104	123	145
Ø D1	24	26	32	45	55	70
Ø D2	24	26	32	45	55	70
Ø Dc	84	100	122	156	185	230
□ F	70 × 70	90 × 90	114 × 114	144 × 144	174 × 174	216 × 216
L1	50	55	65	90	110	140
L11	134	165	197	242	292	358
L2	50	55	65	90	110	140
L22	134	165	197	242	292	358
S	10	8	9	11	11	11
f	M8, depth 20	M10, depth 25	M10, depth 25	M12, depth 30	M14, depth 35	M16, depth 40
h1	M6, depth 12	M8, depth 20	M8, depth 20	M10, depth 25	M10, depth 25	M12, depth 25
h2	M6, depth 12	M8, depth 20	M8, depth 20	M10, depth 25	M10, depth 25	M12, depth 25
k1	8 × 7 × 40	8 × 7 × 45	10 × 8 × 55	14 × 9 × 80	16 × 10 × 100	20 × 12 × 120
k2	8 × 7 × 40	8 × 7 × 45	10 × 8 × 55	14 × 9 × 80	16 × 10 × 100	20 × 12 × 120

Bevel gearboxes BG Series

Overall dimensions: BG •• S H

input: solid shaft, STANDARD diameter

output: hollow shaft

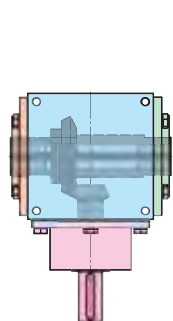
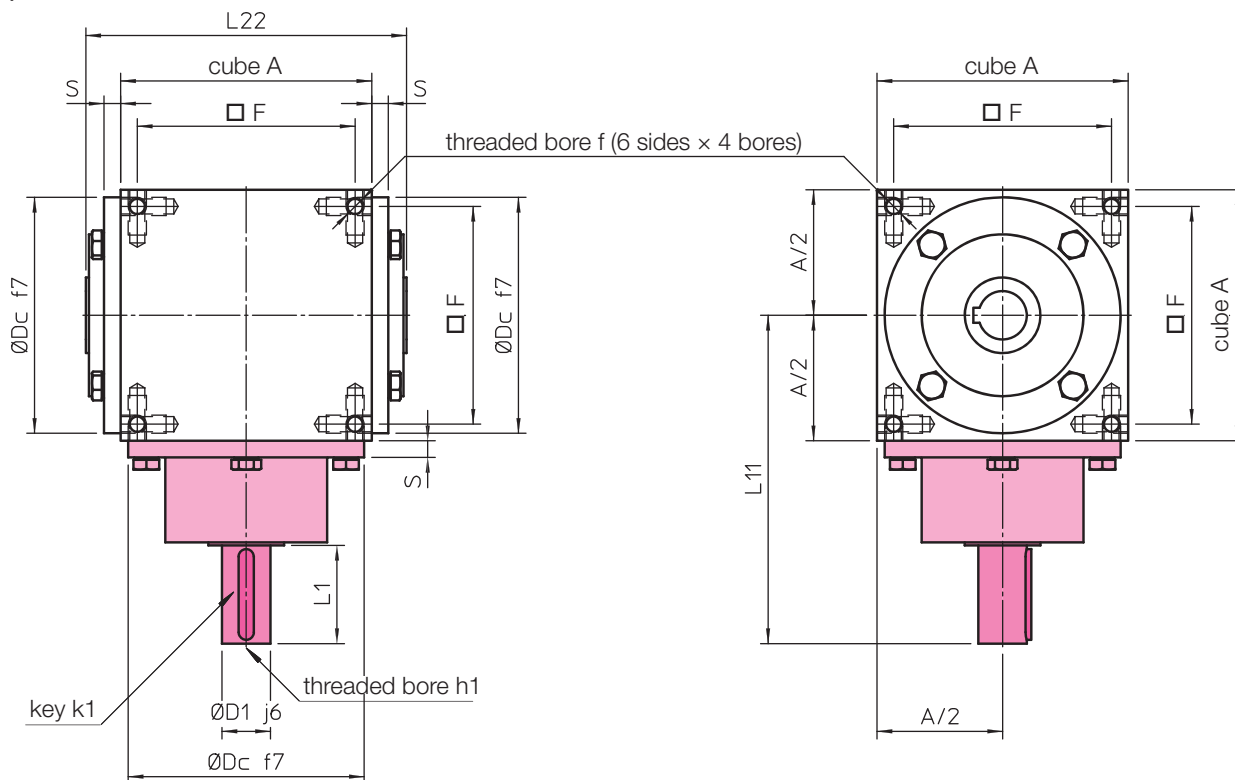

scheme: 10

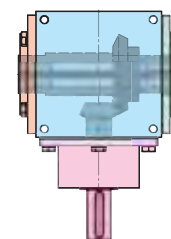
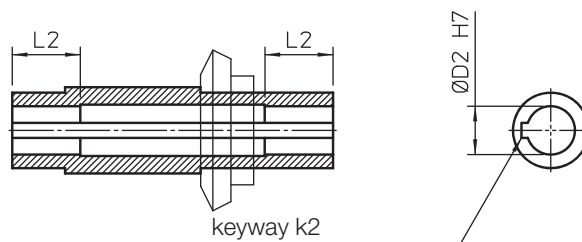

scheme: 20

SIZE	BG 86	BG 110	BG 134	BG 166	BG 200	BG 250
cube A	86 × 86 × 86	110 × 110 × 110	134 × 134 × 134	166 × 166 × 166	200 × 200 × 200	250 × 250 × 250
Ø D1	16	20	24	32	42	55
Ø D2	16	20	24	32	42	55
Ø Dc	84	100	122	156	185	230
□ F	70 × 70	90 × 90	114 × 114	144 × 144	174 × 174	216 × 216
L1	30	40	50	65	85	100
L11	114	150	182	217	267	318
L2	30	30	35	45	50	55
L22	120	144	174	212	250	300
S	10	8	9	11	11	11
f	M8, depth 20	M10, depth 25	M10, depth 25	M12, depth 30	M14, depth 35	M16, depth 40
h1	M6, depth 12	M8, depth 20	M8, depth 20	M10, depth 25	M10, depth 25	M12, depth 25
k1	5 × 5 × 25	6 × 6 × 35	8 × 7 × 45	10 × 8 × 60	12 × 8 × 80	12 × 8 × 80
k2	5 × 5	6 × 6	8 × 7	10 × 8	12 × 8	16 × 10

Bevel gearboxes BG Series

Overall dimensions: BG S

additional output: solid shaft, STANDARD diameter

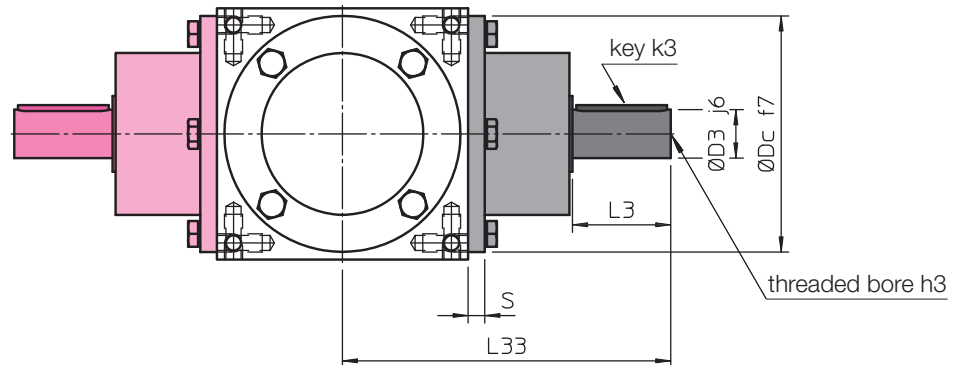

SIZE	BG 86	BG 110	BG 134	BG 166	BG 200	BG 250
cube A	86 × 86 × 86	110 × 110 × 110	134 × 134 × 134	166 × 166 × 166	200 × 200 × 200	250 × 250 × 250
Ø D3	16	20	24	32	42	55
Ø Dc	84	100	122	156	185	230
L3	30	40	50	65	85	100
L33	114	150	182	217	267	318
S	10	8	9	11	11	11
h3	M6, depth 12	M8, depth 20	M8, depth 20	M10, depth 25	M10, depth 25	M12, depth 25
k3	5 × 5 × 25	6 × 6 × 35	8 × 7 × 45	10 × 8 × 60	12 × 8 × 80	16 × 10 × 90

Overall dimensions: BG R

additional output: solid shaft, LARGER diameter

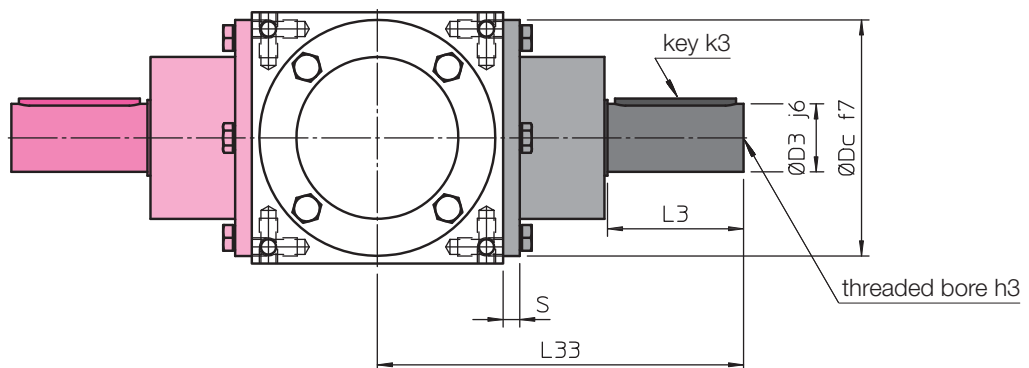

SIZE	BG 86	BG 110	BG 134	BG 166	BG 200	BG 250
cube A	86 × 86 × 86	110 × 110 × 110	134 × 134 × 134	166 × 166 × 166	200 × 200 × 200	250 × 250 × 250
Ø D3	24	26	32	45	55	70
Ø Dc	84	100	122	156	185	230
L3	50	55	65	90	110	140
L33	134	165	197	242	292	358
S	10	8	9	11	11	11
h3	M6, depth 12	M8, depth 20	M8, depth 20	M10, depth 25	M10, depth 25	M12, depth 25
k3	5 × 5 × 25	6 × 6 × 35	8 × 7 × 45	10 × 8 × 60	12 × 8 × 80	16 × 10 × 90

Bevel gearboxes BG Series

Overall dimensions: BG • • MF

input: IEC motor flange and hollow shaft with keyway

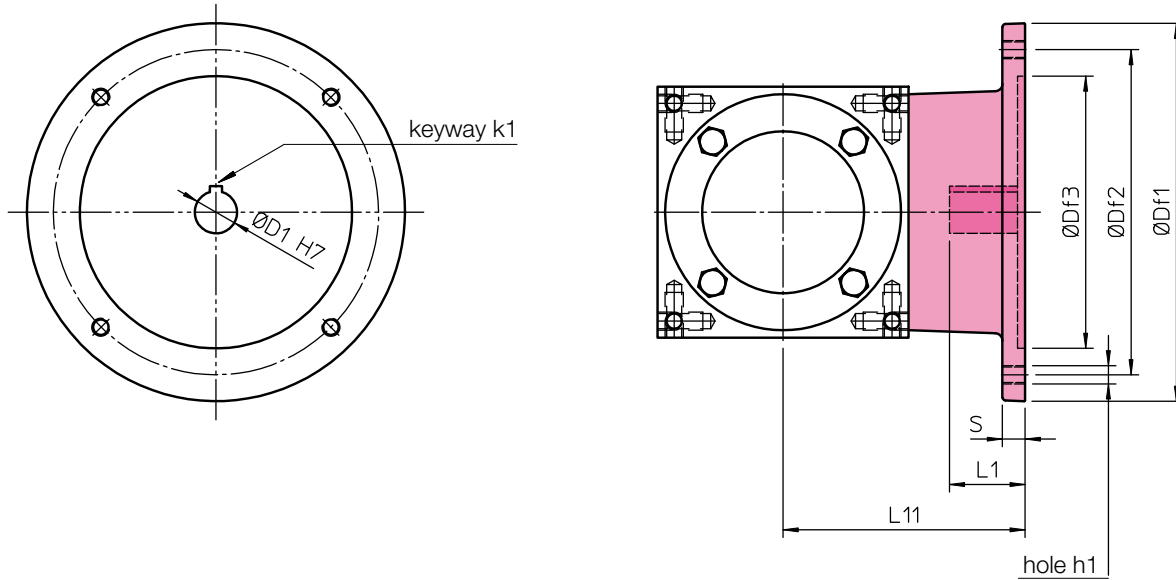

SIZE	IEC motor	$\varnothing D1$	$\varnothing Df1$	$\varnothing Df2$	$\varnothing Df3$	L1	L11	h1	k1	s
BG 86	71 B5	14	160	130	110	30	90	M8	5 × 5	13
	80 B5	19	200	165	130	40	100	M10	6 × 6	13
	80 B14	19	120	100	80	40	100	$\varnothing 7$	6 × 6	13
BG 110	80 B5	19	200	165	130	40	105	M10	6 × 6	13
	80 B14	19	120	100	80	40	105	$\varnothing 7$	6 × 6	13
	90 B5	24	200	165	130	50	115	M10	8 × 7	13
	90 B14	24	140	115	95	50	115	$\varnothing 9$	8 × 7	13
BG 134	90 B5	24	200	165	130	50	125	M10	8 × 7	13
	100-112 B5	28	250	215	180	60	135	M12	8 × 7	13
	100-112 B14	28	160	130	110	60	135	$\varnothing 9$	8 × 7	13
BG 166	90 B5	24	200	165	130	50	160	M10	8 × 7	15
	100-112 B5	28	250	215	180	60	160	M12	8 × 7	15
	100-112 B14	28	160	130	110	60	160	$\varnothing 9$	8 × 7	15
BG 200	100-112 B5	28	250	215	180	60	220	M12	8 × 7	23
	132 B5	38	300	265	230	80	220	M12	10 × 8	23
	132 B14	38	200	165	130	80	220	$\varnothing 11$	10 × 8	23
BG 250	132 B5	38	300	265	230	80	250	M12	10 × 8	25
	160 B5	42	350	300	250	110	250	M16	12 × 8	25

Bevel gearboxes BG Series

Special arrangements

- special flange (code: **BG • • MA**) for servomotors or hydraulic motors, shaft fixed with clamp or shrink disk

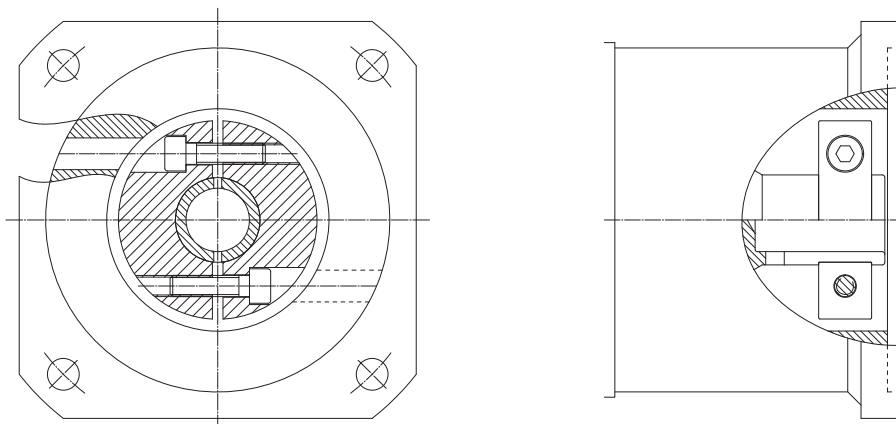

- input and output shafts with spline profile DIN 5480

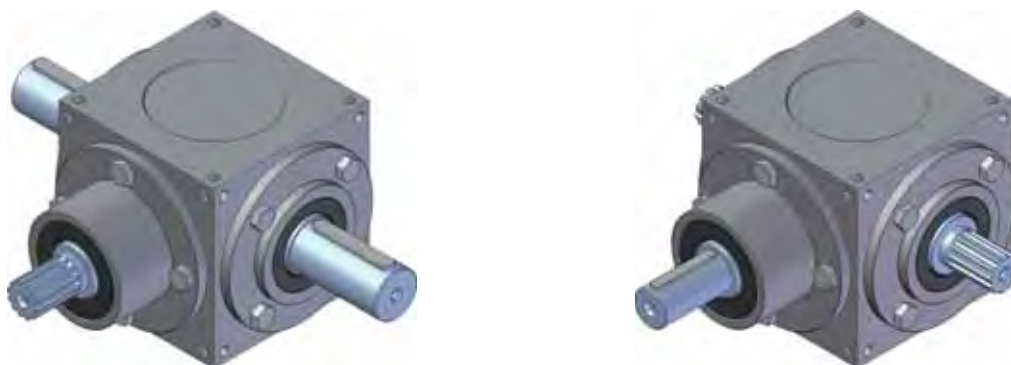

- output hollow shafts with shrink disks

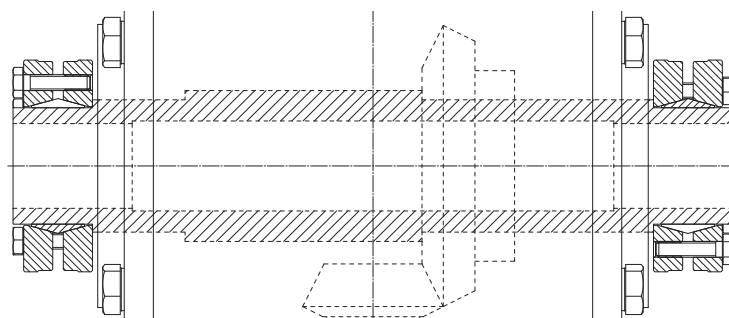

- output hollow shaft broached with spline profile according to ISO 14

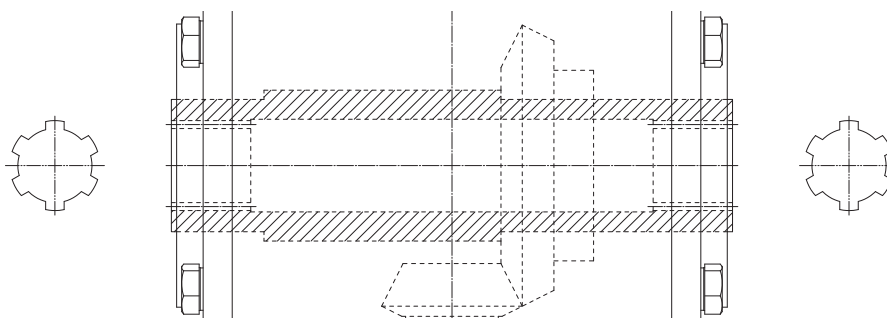

- chemical nickel-plating treatment NIPLOY on housings, covers and hubs
- housings, covers and shafts available in stainless steel AISI 304 or AISI 316

Bevel gearboxes BG Series

Mounting and operating position

The operating position of the bevel gearbox is important for an optimal lubrication of gears and bearings, as well as for the right definition of the oil plug and air breather position (if present).

Following schemes show the bevel gearbox with input solid shaft (**S** or **R**) but they can also be applied for gearboxes with IEC motor flange (**MF**). In case of gearboxes with additional output shafts, please refer to the same schemes to define the input and main output position of the gearbox, the position of the additional output shafts can be identified consequently.

Bevel gearbox with output shaft M2

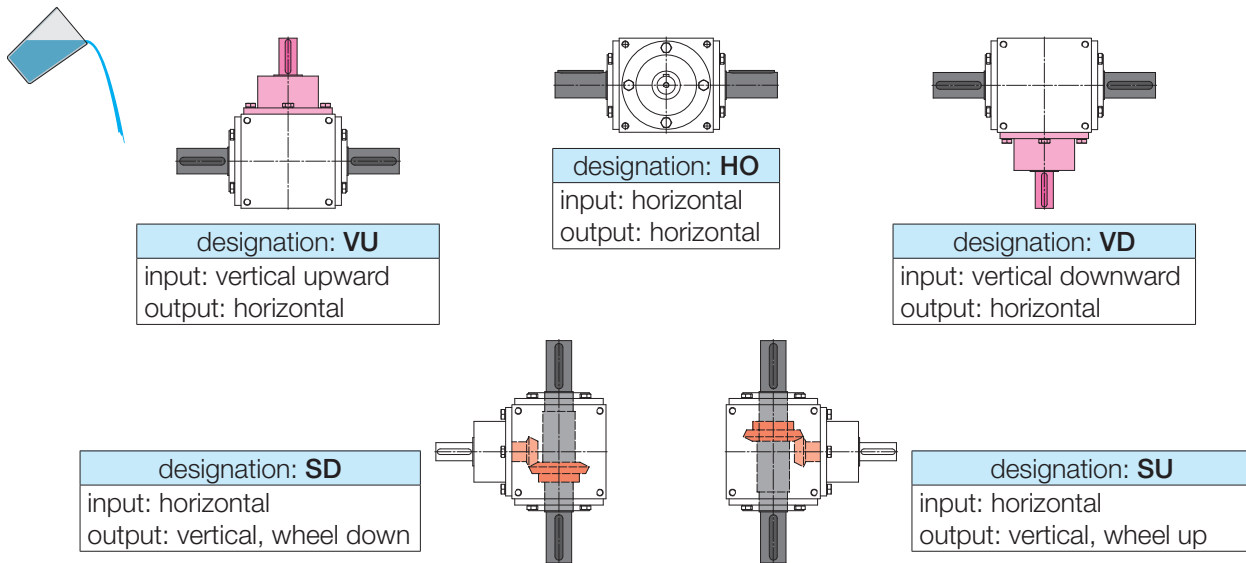

Bevel gearbox with output shaft M1

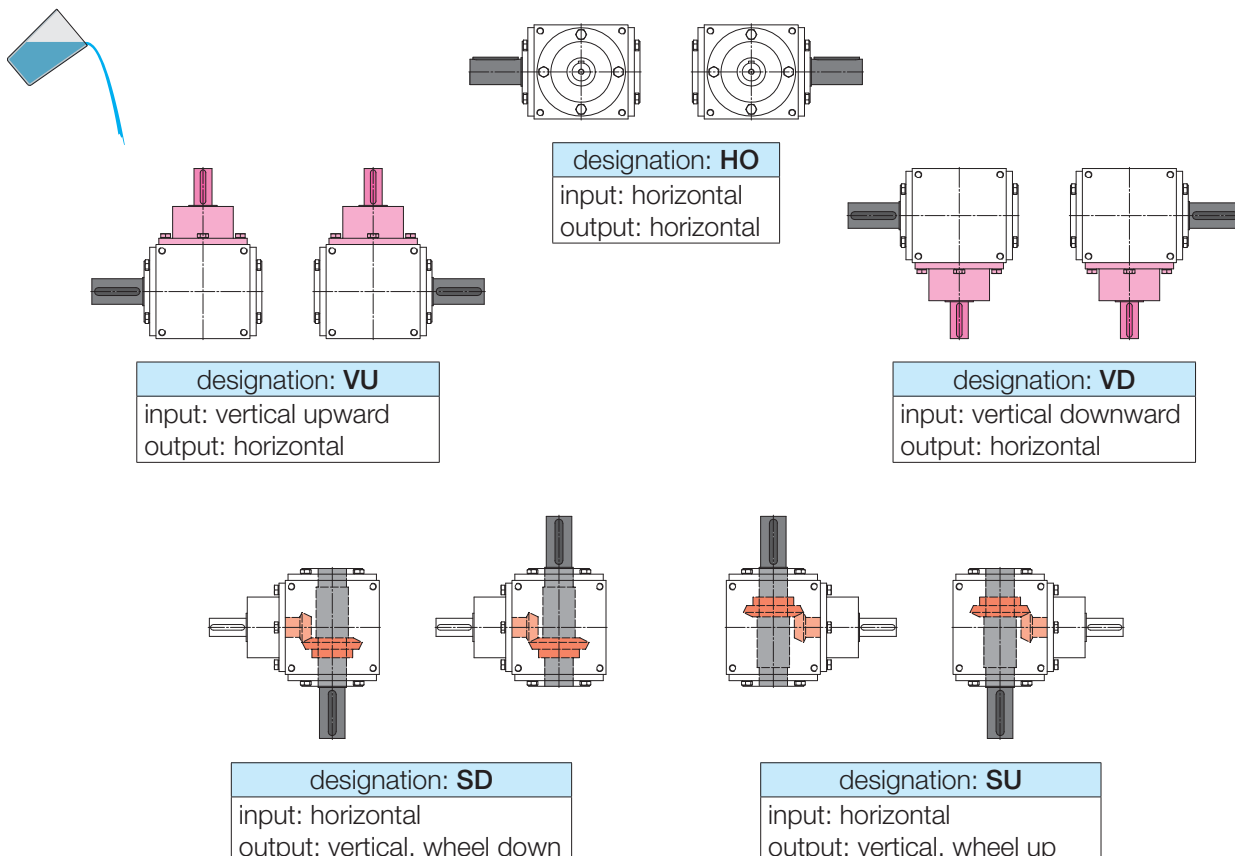

Bevel gearboxes BG Series

Mounting and operating position

Bevel gearbox with output shaft H

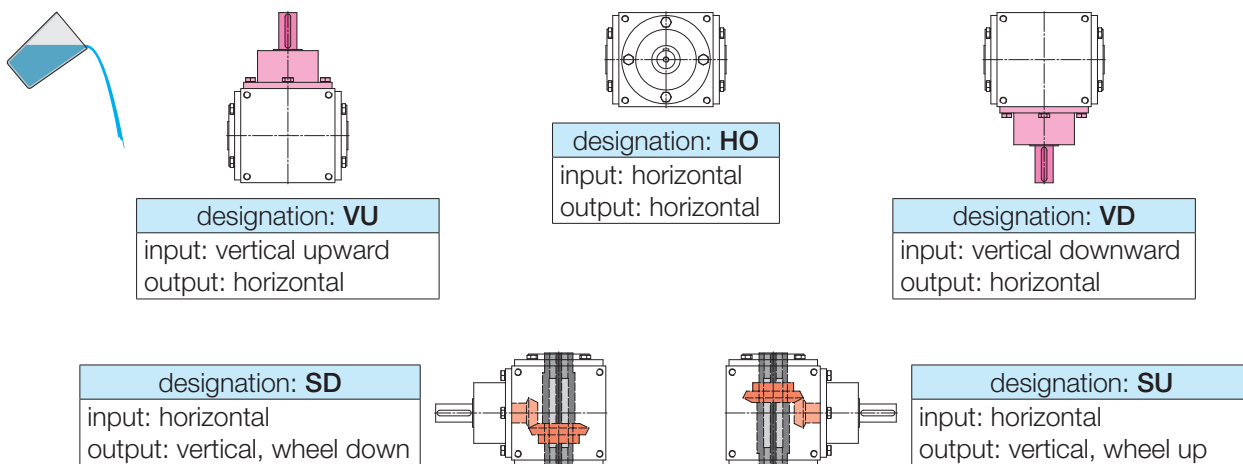

Bevel gearbox with output shaft S1 or R1

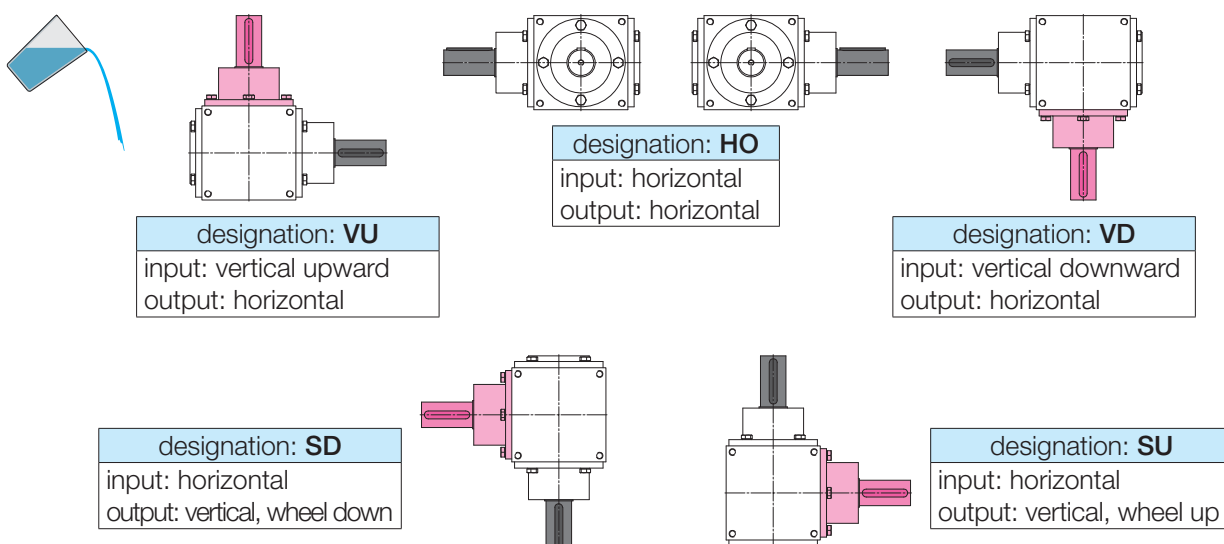

Bevel gearbox with output shaft S2 or R2

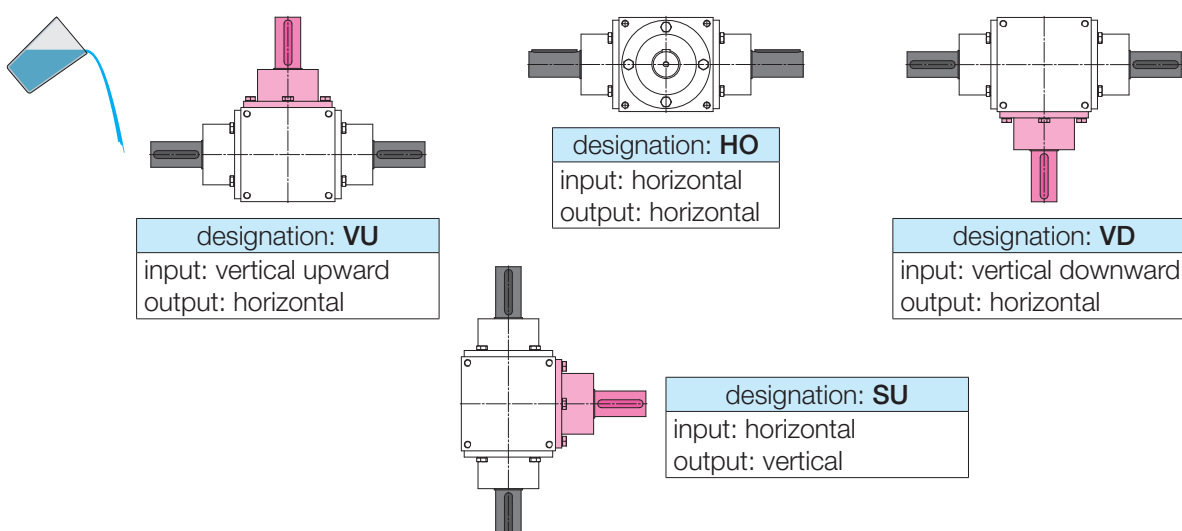

Bevel gearboxes BG Series

Kinematic scheme, direction of shaft rotation

Bevel gearbox with main output only

Following schemes refer to the bevel gearbox with a solid shaft (**S** or **R**) as input. The indications of the direction of the shaft rotation are also valid for bevel gearboxes with input with motor flange:

- MF - flange for IEC electric motors
- MA - special flanges for servomotors or hydraulic motors

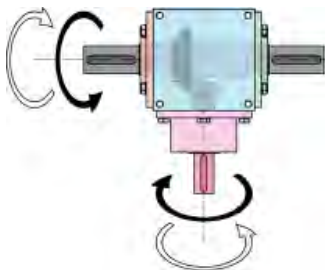

scheme: 10

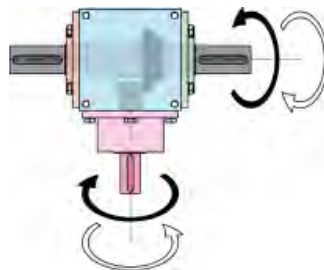

scheme: 20

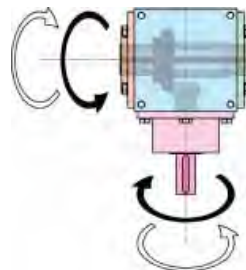

scheme: 10

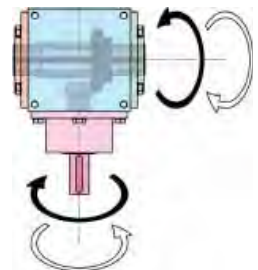

scheme: 20

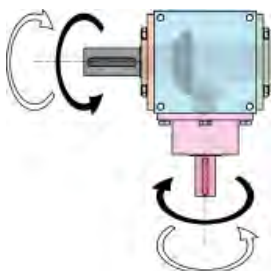

scheme: 30

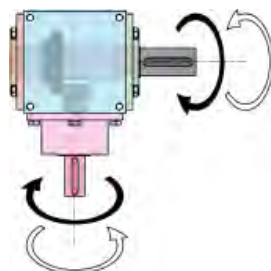

scheme: 40

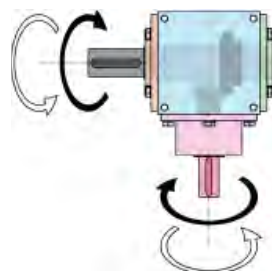

scheme: 50

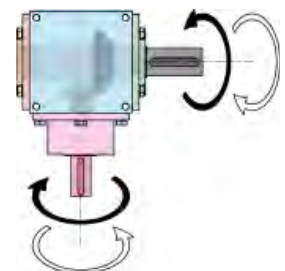

scheme: 60

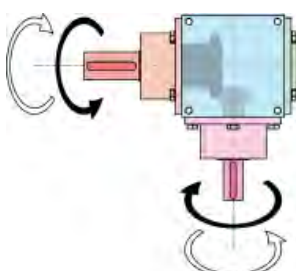

scheme: 70

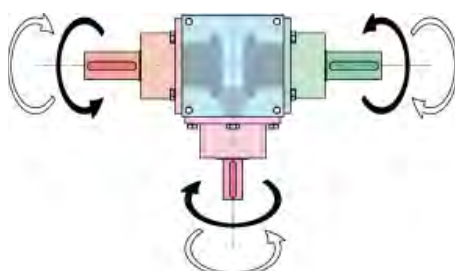

scheme: 80

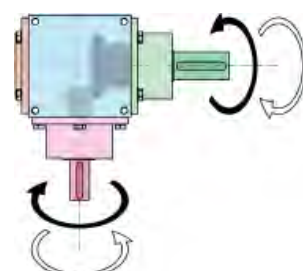

scheme: 90

Bevel gearboxes BG Series

Kinematic scheme, direction of shaft rotation

Bevel gearbox with 1 (one) additional output shaft on side D

Following schemes refer to the bevel gearbox with solid shaft (**S** o **R**) as input and with only one solid shaft with hub (**S** o **R**) as additional output on side D. The indications of the shaft rotation are also valid for bevel gearboxes with IEC motor flange (**MF**) as input.

Designation of kinematic scheme of the bevel gearbox with 1 (one) additional output shaft: add **1.** to the code of the scheme for bevel gearbox without additional output shaft (page 30).

WARNING! The rotation speed of the additional output shaft is always equal to the input shaft rotation speed, independently of the bevel gear ratio!

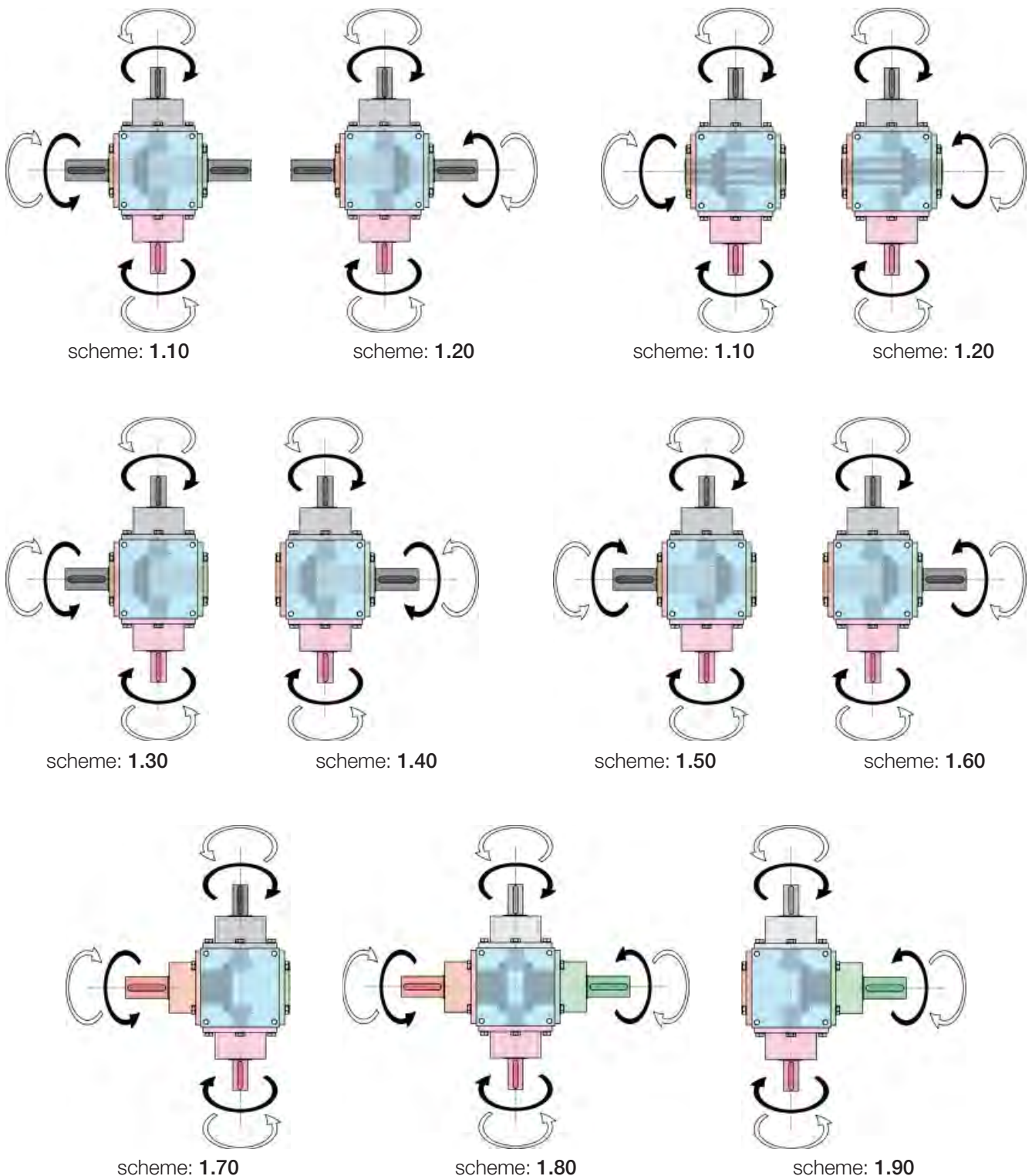

Bevel gearboxes BG Series

Kinematic scheme, direction of shaft rotation

Bevel gearbox with 1 (one) additional output shaft

Following schemes refer to the bevel gearbox with solid shaft (S o R) as input, with a solid shaft M2 as main output and with only one solid shaft (S o R) as additional output. The indications of the direction of the shaft rotation are also valid for bevel gearboxes with IEC motor flange (MF) as input and/or with single solid shaft M1 or hollow shaft H as main output.

Designation of kinematic scheme of the bevel gearbox with 1 (one) additional output shaft: add 1. to the code of the scheme without additional output shaft (page 30) and indicate the side of the additional output.

WARNING! The rotation speed of the additional output shaft is always equal to the input shaft rotation speed, independently of the bevel gear ratio!

(⚠) Versions marked with symbol ⚠ are not available with ratio 1 : 1.

scheme: 1.10
side: F

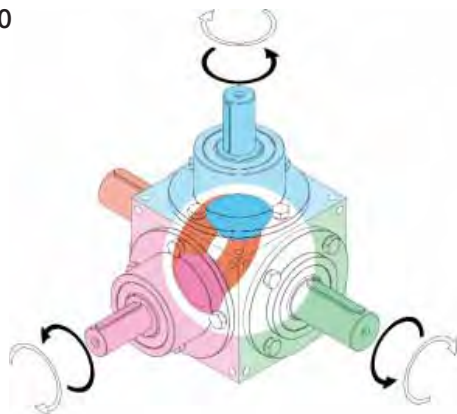

scheme: 1.20
side: F

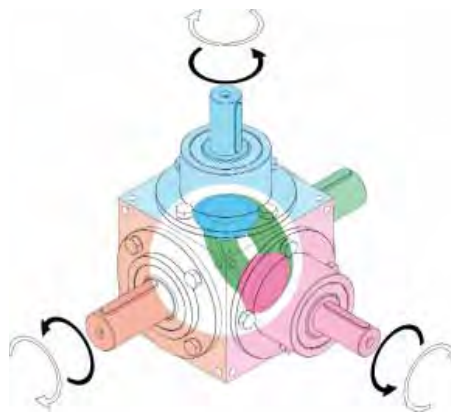

scheme: 1.10
side: D

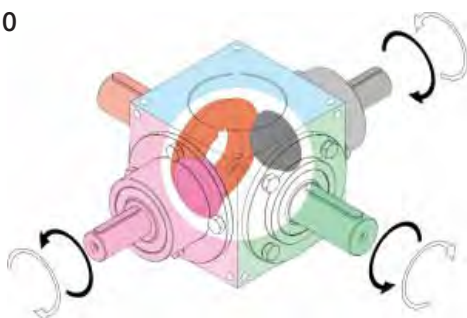

scheme: 1.20
side: D

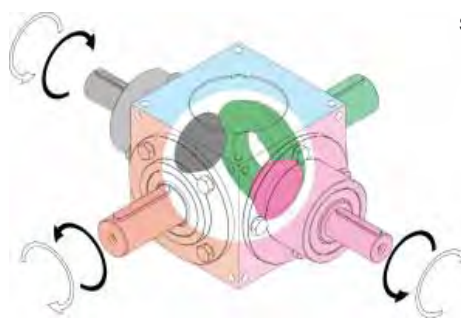

scheme: 1.10
side: E

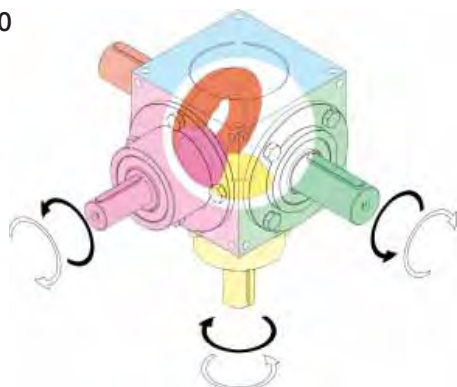

scheme 1.20
side: E

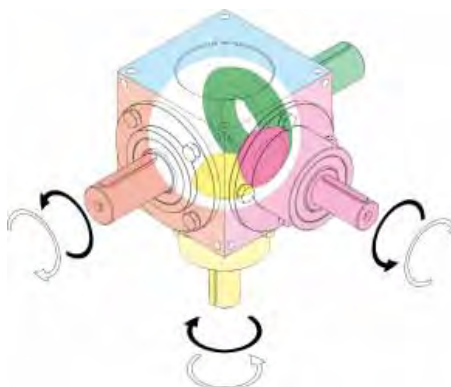

Kinematic scheme, direction of shaft rotation

Bevel gearbox with 1 (one) additional output shaft

Following schemes refer to the bevel gearbox with a solid shaft (**S** o **R**) as input, with two solid shafts with hub (**S2** o **R2**) as main output and with only one solid shaft (**S** o **R**) as additional output. The indications of the direction of the shaft rotation are also valid for bevel gearboxes with IEC motor flange (**MF**) as input and/or with single solid shaft with hub (**S1** o **R1**) as main output.

Designation of kinematic scheme of the bevel gearbox with 1 (one) additional output shaft: add **1.** to the code of the scheme without additional output shaft (page 30) and indicate the side of the additional output.

WARNING! The rotation speed of the additional output shaft is always equal to the input shaft rotation speed, independently of the bevel gear ratio!

(⚠) Versions marked with symbol ⚠ are not available with ratio 1 : 1.

scheme: 1.80
side: F

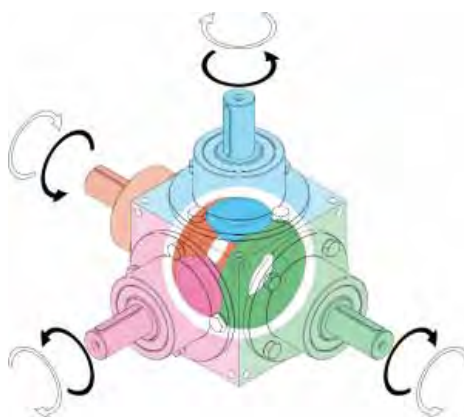

scheme: 1.80
side: D

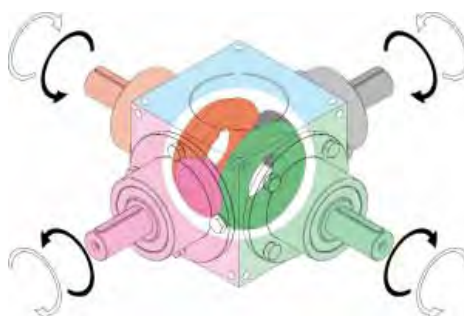

scheme: 1.80
side: E

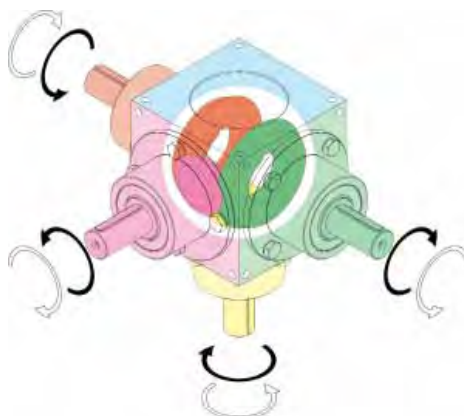

Bevel gearboxes BG Series

Kinematic scheme, direction of shaft rotation

Bevel gearbox with 2 (two) additional output shafts

Following schemes refer to the bevel gearbox with a solid shaft (**S** o **R**) as input, with a solid shaft **M2** as main output and with two solid shafts (**S** o **R**) as additional output. The indications of the direction of the shaft rotation are also valid for bevel gearboxes with IEC motor flange (**MF**) as input and/or with single solid shaft **M1** or hollow shaft **H** as main output.

Designation of kinematic scheme of the bevel gearbox with 2 (two) additional output shafts: add **2.** to the code of the scheme without additional output shaft (page 30) and indicate the side of the additional output.

WARNING! The rotation speed of the additional output shaft is always equal to the input shaft rotation speed, independently of the bevel gear ratio!

(⚠) Versions marked with symbol ⚠ are not available with ratio 1 : 1.

scheme: 2.10
side: D-F

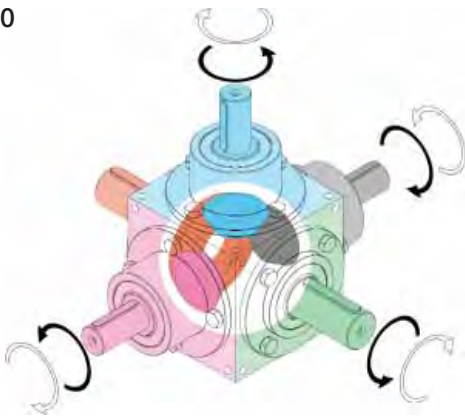

scheme: 2.10
side: D-E

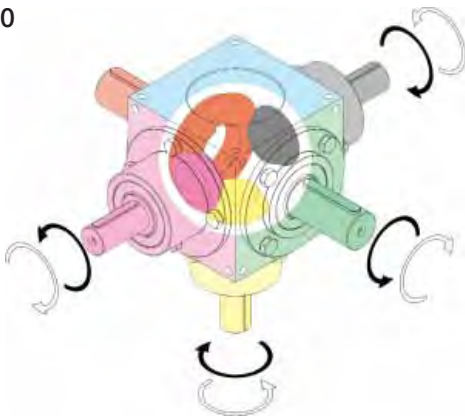

scheme: 2.10
side: E-F

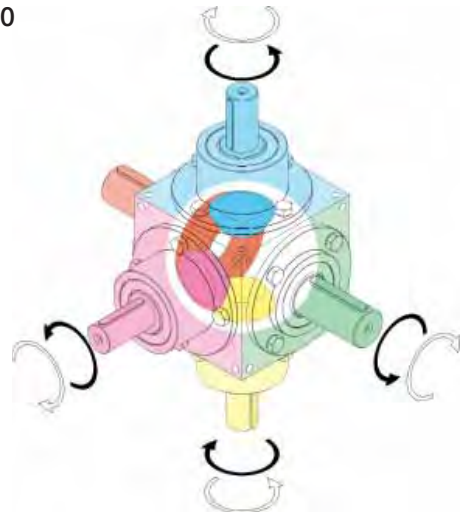

scheme: 2.20
side: D-F

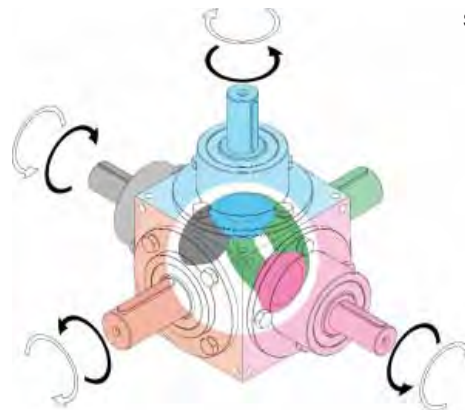

scheme: 2.20
side: D-E

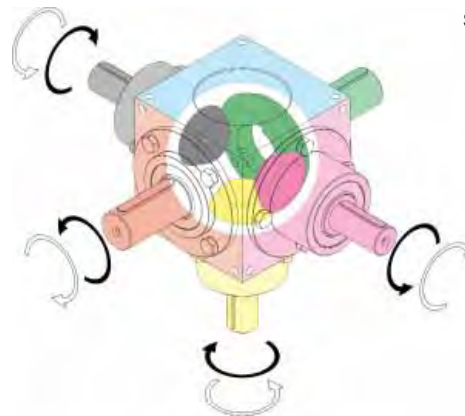

scheme: 2.20
side: E-F

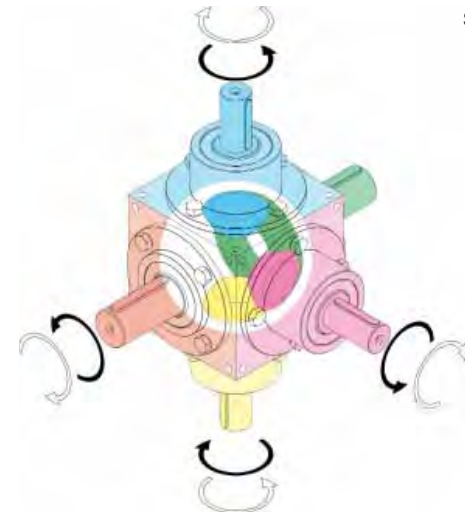

Bevel gearboxes BG Series

Kinematic scheme, direction of shaft rotation

Bevel gearbox with 2 (two) additional output shafts

Following schemes refer to the bevel gearbox with a solid shaft (**S** o **R**) as input, with two solid shafts with hub (**S2** o **R2**) as main output and with two solid shafts (**S** o **R**) as additional output. The indications of the direction of the shaft rotation are also valid for bevel gearboxes with IEC motor flange (**MF**) as input and/or with a single solid shaft with hub (**S1** o **R1**) as main output.

Designation of kinematics scheme of the bevel gearbox with 2 (two) additional output shafts: add **2.** to the code of the scheme without additional output shaft (page 30) and indicate the side of the additional output.

WARNING! The rotation speed of the additional output shaft is always equal to the input shaft rotation speed, independently of the bevel gear ratio!

(⚠) Versions marked with symbol ⚠ are not available with ratio 1:1.

scheme: 2.80
side: D-F

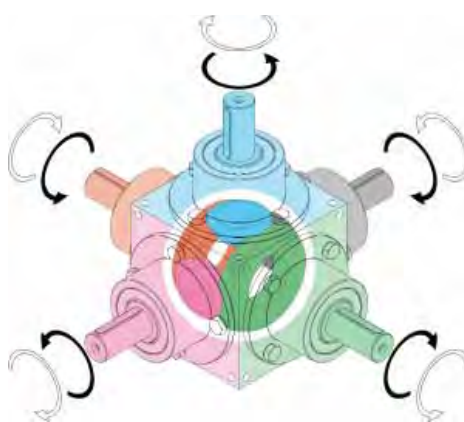

scheme: 2.80
side: D-E

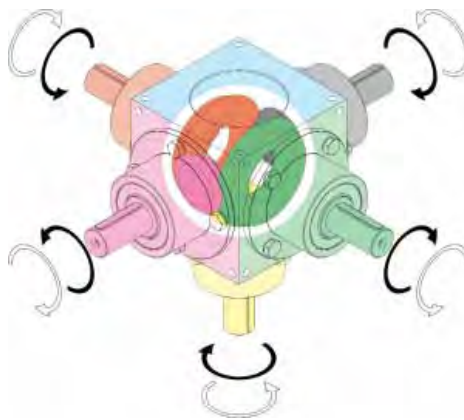

scheme: 2.80
side: E-F

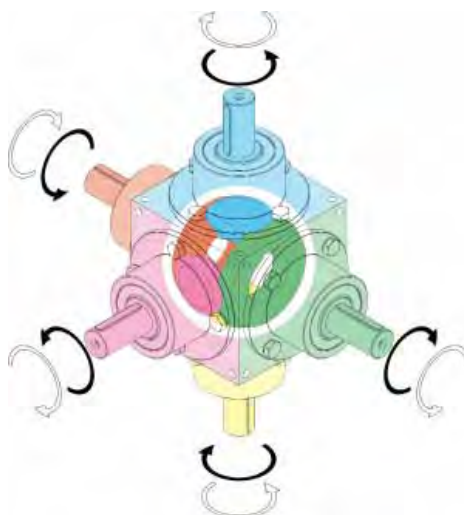

Bevel gearboxes BG Series

Kinematic scheme, direction of shaft rotation

Bevel gearbox with 3 (three) additional output shafts

Following schemes refer to the bevel gearbox with a solid shaft (**S** o **R**) as input, with a solid shaft **M2** as main output and with three solid shafts (**S** o **R**) as additional output. The indications of the direction of the shaft rotation are also valid for bevel gearboxes with IEC motor flange (**MF**) as input and/or with single solid shaft **M1** or hollow shaft **H** as main output.

scheme: 3.10

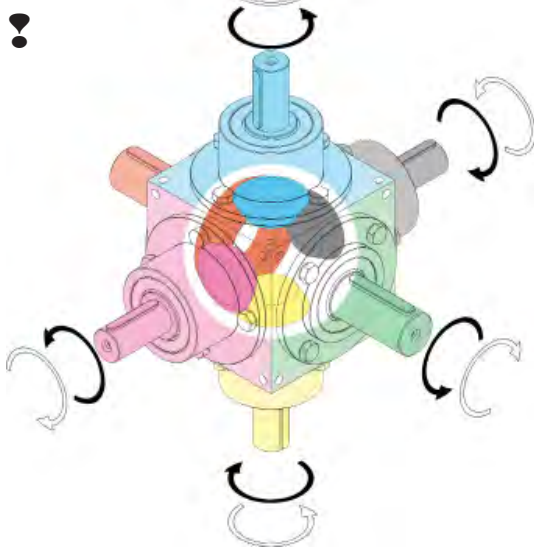

scheme: 3.20



Following schemes refer to the bevel gearbox with a solid shaft (**S** o **R**) as input, with two solid shafts with hub (**S2** o **R2**) as main output and with three solid shafts (**S** o **R**) as additional output. The indications of the shaft rotation are also valid for bevel gearboxes with IEC motor flange (**MF**) as input and/or with single solid shaft with hub (**S1** o **R1**) as main output.

scheme: 3.80

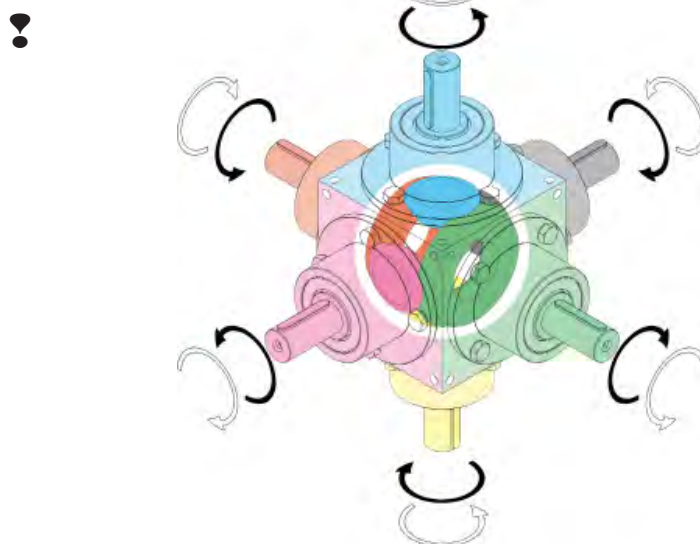

Designation of kinematics scheme of the bevel gearbox with 3 (three) additional output shafts: add **3**. to the code of the scheme without additional output shaft (page 30).

WARNING! The rotation speed of the additional output shaft is always the same as the input shaft rotation speed, independently of the bevel gear ratio!

(?) Versions marked with symbol ? are not available with ratio 1:1.

Bevel gearbox efficiency (η)

The efficiency of the bevel gears with GLEASON spiral toothing, lapped in pairs, basically is not influenced by the ratio and/or by the rotation input speed.

Furthermore, it has no remarkable variations by varying the gearbox size.

The value $\eta = 0.97$, result of calculated average values, is assumed as a reasonable average value.

On the contrary, the efficiency of bearings and oil seals, mounted on the input and output shafts, depends on the rotation speed and the ratio.

Generally, it varies from 0.96 to 0.93 by changing from the minimum rotation speed of the shafts up to the maximum speed, referring to the **Nominal performances**.

The above considerations bring to average values of the bevel gearbox total efficiency in a range within 0.90 ... 0.93.

Angular backlash

The standard angular backlash on the output shaft, with input shaft locked, is lower than or equal to 10 arcmin.

Therefore, 10 arcmin is assumed as maximum value of the standard backlash.

On request, bevel gears with the gear set to obtain a lower backlash on the output shafts can be supplied. The value of the reduced backlash is lower than (5 ... 6) arcmin.

Radial and axial forces on the shafts

The following table shows the maximum permissible radial (F_{R1} , F_{R2}) and axial (F_{A1} , F_{A2}) forces on the bevel gearbox input and output shafts, with reference to 1500 rpm input speed and the performances shown in the **Nominal performances** table on page 12 - 13.

Operating conditions different from the indicated reference conditions require a specific verification.

SIZE	INPUT SHAFT		OUTPUT SHAFT	
	F_{R1} [N]	F_{A1} [N]	F_{R2} [N]	F_{A2} [N]
BG 86	510	45	600	180
BG 110	600	180	1800	540
BG 134	1200	360	2500	750
BG 166	1800	540	3500	1000
BG 200	2500	750	4500	1350
BG 250	3800	1150	6500	1900

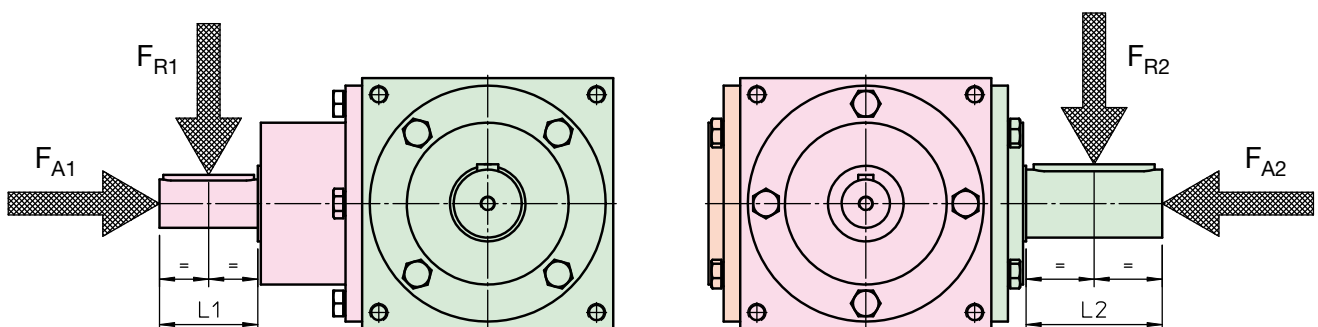

Bevel gearboxes BG Series

Moment of inertia of rotating mass

Following tables show the moment of inertia of the bevel gearbox rotating mass, referred to the input axis, expressed in $\text{kg}\cdot\text{cm}^2$.

Design: standard solid input shaft (S) - output shaft on both sides (M2):

DESIGN	SIZE	Moment of inertia referred to input axis [$\text{kg}\cdot\text{cm}^2$]				
		Ratio R 1	Ratio R 1.5	Ratio R 2	Ratio R 3	Ratio R 4
 BG . . . S M2	BG 86	3.5	2.0	1.5	1.2	1.1
	BG 110	7.6	3.4	2.3	1.5	1.3
	BG 134	21	11	7.5	5.6	4.9
	BG 166	73	37	27	20	17
	BG 200	176	92	67	50	43
	BG 250	595	317	233	177	158

Design: connection for IEC motor (MF) as input - output shaft on both sides (M2):

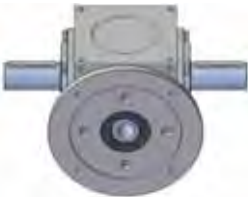
DESIGN	SIZE	Moment of inertia referred to input axis [$\text{kg}\cdot\text{cm}^2$]				
		Ratio R 1	Ratio R 1.5	Ratio R 2	Ratio R 3	Ratio R 4
 BG . . . MF M2	BG 86	5.1	4.8	4.7	4.7	4.6
	BG 110	11.1	6.9	5.8	5.0	4.8
	BG 134	24	14	11	8.9	8.2
	BG 166	73	36	26	19	16
	BG 200	174	90	65	48	41
	BG 250	594	311	226	170	151

Bevel gearboxes BG Series

Ordering code

BG	166	R2	S	M2	scheme 1.20	S	F	E	HO	...
	1	2	3	4	5	6	7	8	9	10

1	Bevel gearbox size 86 - 110 - 134 - 166 - 200 - 250	pg. 10 - 11
2	Ratio R1 - R1.5 - R2 - R3 - R4	pg. 10 - 11
3	Main gearbox input S - solid shaft, cylindrical with key, STANDARD diameter R - solid shaft, cylindrical with key, LARGE diameter MF - IEC motor flange and hollow shaft with keyway MA - special motor flange adapter	pg. 14
4	Main gearbox output M1 - solid shaft, cylindrical with key, on one side M2 - solid shaft, cylindrical with key, on both sides H - hollow shaft with cylindrical hole and keyway S1 - solid shaft with hub, cylindrical with key, STANDARD diameter R1 - solid shaft with hub, cylindrical with key, LARGE diameter S2 - two solid shafts with hub, cylindrical with key, STANDARD diameter R2 - two solid shafts with hub, cylindrical with key, LARGE diameter	pg. 15
5	Kinematic scheme	pg. 30 ... 36
6	Additional gearbox output S - solid shaft, cylindrical with key, STANDARD diameter R - solid shaft, cylindrical with key, LARGE diameter	pg. 15
7	Housing side with additional output D - E - F	pg. 15
8	Mounting side A - B - C - D - E - F	pg. 14
9	Operating position HO - VD - VU - SD - SU	pg. 28 - 29
10	Other specifications example: lubricant type – grease (standard) or oil (on request) example: ambient temperature ____°C	

Example:

BG 134 R1.5 S M2 10 _ _ E HO

BG 166 R1 MF (IEC 112 B14) H 1.20 S F D VU

Bevel gearboxes BG Series

Product label

Each SERVOMECH bevel gearbox is supplied with an identification label, as shown below, which allows to identify the gearbox and contains technical information about the product.

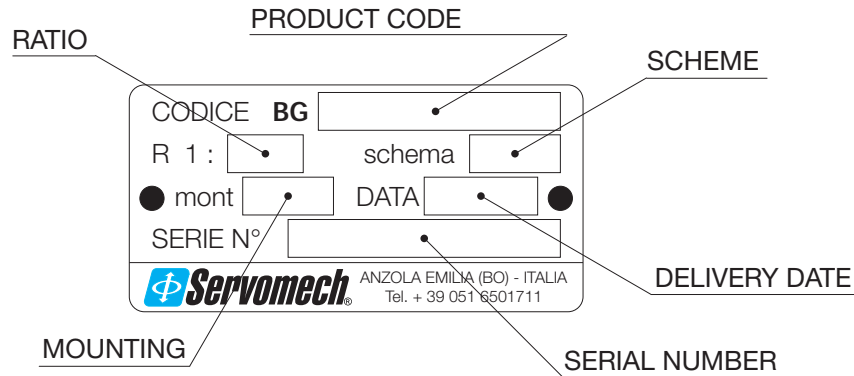

- Product code:** alphanumeric code which identifies the size and the execution of the bevel gearbox;
- Ratio:** ratio of the gearbox;
- Scheme:** kinematic scheme related to the direction of the shaft's rotation;
- Mounting:** mounting and working position of the bevel gearbox;
- Delivery date:** date of assembling, expressed in week and year (example: 07/12 = week 07 / year 2012) which usually coincide with the delivery week; this date is considered as reference for the warranty period;
- Serial number:** identification number of the bevel gearbox which ensures the individuation of the product even after a long time; the serial number must be indicated in case of spare parts orders.

Bevel gearboxes BG Series

Lubrication and maintenance

SERVOMECH bevel gearboxes BG Series are supplied already lubricated.

Standard lubrication with grease, suitable for applications with low input speed and low daily duty cycle.

For applications with high speeds and/or high daily duty cycle oil lubrication is recommended. In such cases, the gearbox housing is equipped with oil plugs and visual oil level indicator, while the air breather is supplied as separate component and must be fitted by the customer on the top upon installation.

Grease-lubricated gearboxes are maintenance-free. With no occasional seals damage nor disassembling of components due to maintenance, an inspection every 4 years, in case of daily operation up to 8 hours, is sufficient.

Oil-lubricated gearboxes require the first oil change after 500 operating hours and thereafter every 3000 operating hours.

Recommended type of lubricant, based on input speed												
Size	grease lubrication						oil lubrication				Q.ty	
											grease [kg]	oil [l]
BG 86											0.2	0.22
BG 110											0.4	0.45
BG 134											0.5	0.55
BG 166											1	1.1
BG 200											2.5	2.8
BG 250											5	5.5

Input speed [rpm]

NOTE: the quantity of oil lubricant, expressed in litres, is approximate; please refer to the oil level for a correct filling.

Operating conditions different from the above should be specified for a correct evaluation and choice of lubricant type and quantity.

Mounting positions where input and output shafts are not all on the horizontal plane should be specified to evaluate the correct lubrication of the bearings and the shafts mounted on the vertical top position.

By ordering, please specify lubrication requirements: **grease** or **oil**.

Recommended lubricants:

grease: AGIP Grease SLL 00 (first filling) or SHELL Gadus S5 V142W

oil: AGIP Blasia S 220 (first filling) or SHELL Omala S4 GX

Bevel gearboxes BG Series

Spare parts bevel gearboxes with output shaft M1 or M2 or H

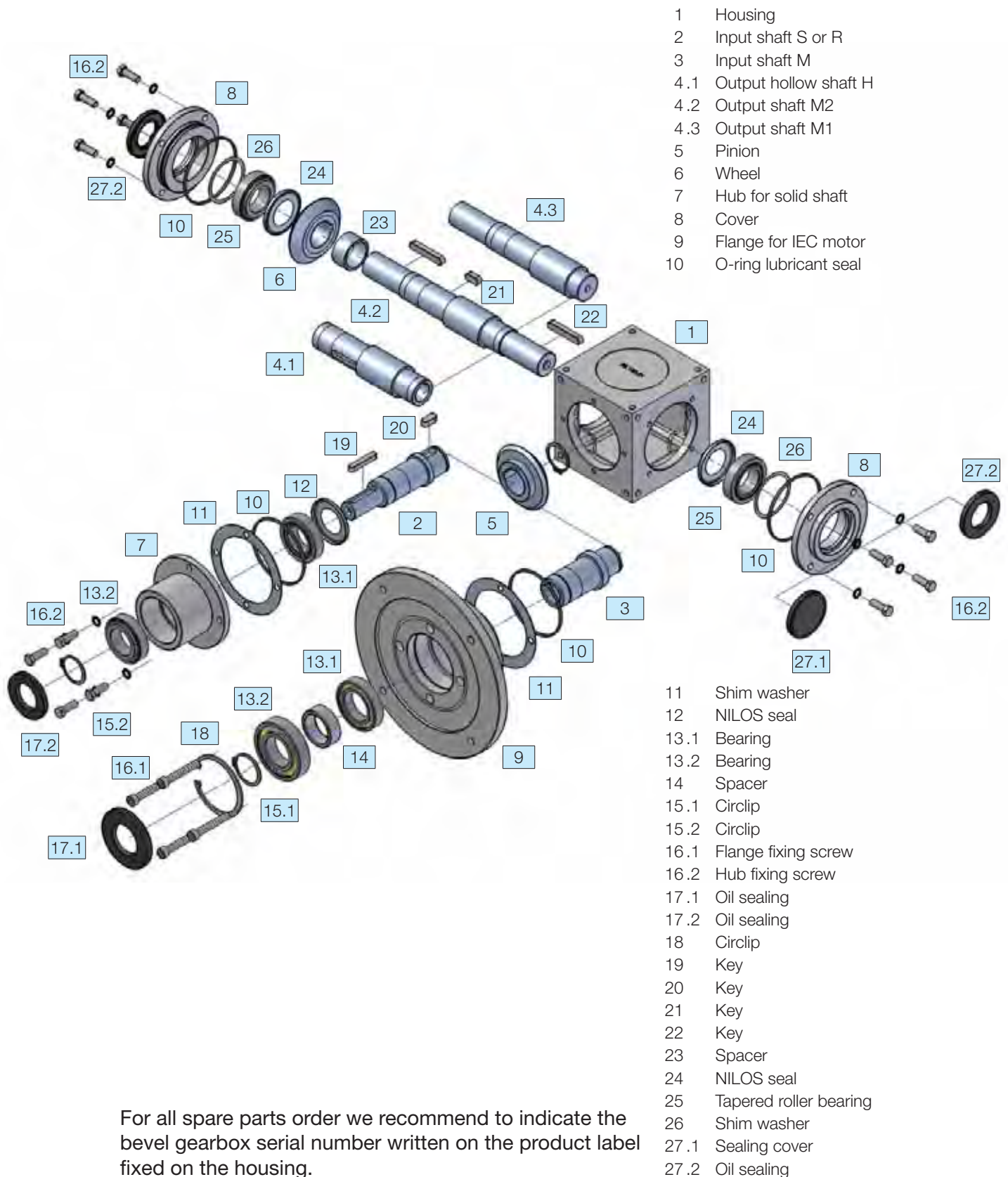

For all spare parts order we recommend to indicate the bevel gearbox serial number written on the product label fixed on the housing.

Bevel gearboxes BG Series

Spare parts bevel gearboxes with output shaft S1 o R1

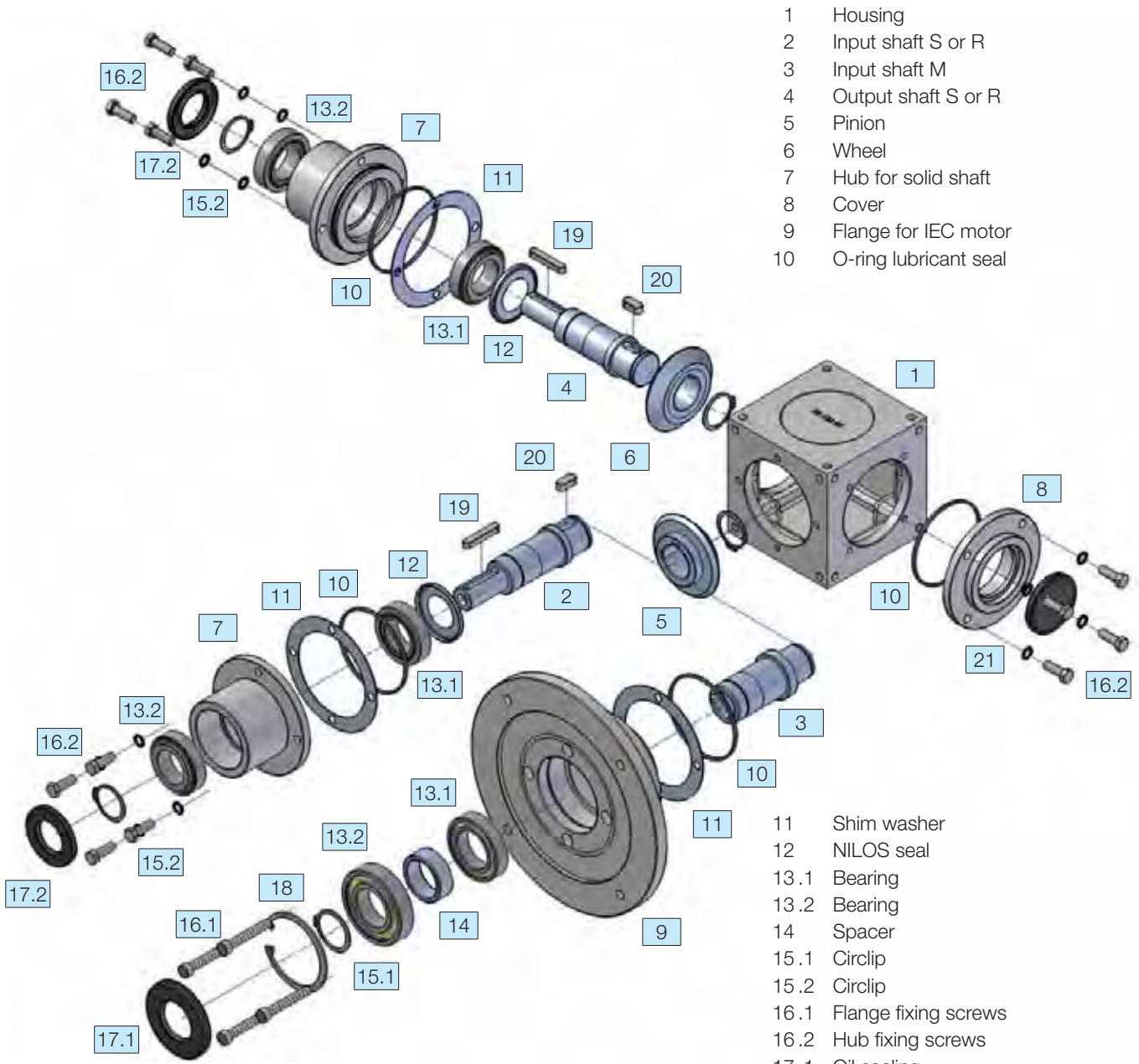

- 1 Housing
- 2 Input shaft S or R
- 3 Input shaft M
- 4 Output shaft S or R
- 5 Pinion
- 6 Wheel
- 7 Hub for solid shaft
- 8 Cover
- 9 Flange for IEC motor
- 10 O-ring lubricant seal

- 11 Shim washer
- 12 NILOS seal
- 13.1 Bearing
- 13.2 Bearing
- 14 Spacer
- 15.1 Circlip
- 15.2 Circlip
- 16.1 Flange fixing screws
- 16.2 Hub fixing screws
- 17.1 Oil sealing
- 17.2 Oil sealing
- 18 Circlip
- 19 Key
- 20 Key
- 21 Sealing cover

For all spare parts order we recommend to indicate the bevel gearbox serial number written on the product label fixed on the housing.

Bevel gearboxes BG Series

General deliveries conditions

Without any required specifications, SERVOMECH bevel gearboxes are supplied in following execution:

- lubrication: grease or oil, depending on the input speed according to the table on page 41. In case of oil lubrication, the breather is supplied as separate component and should be fitted by the user in the top position upon installation and before the start-up. The gearboxes are supplied with oil plugs and oil level indicator fitted in the position as indicated in the ordering code (see **Mounting and operating position** on pages 28-29 and the **Ordering code** on page 39);
- painting: housing, covers and hubs in grey cast iron with 1 coating of protective primer grey colour RAL 7040, on request finish coating in grey colour RAL 7012 with extra charge. Furthermore, special painting cycles can be done on request, with bi-component epoxy paints in the required colour, which are quoted separately;
- shafts protection: input shafts and output solid shafts with key are protected with removable plastic covers;
- packaging: the packaging is agreed with the customer based on quantity of the products, final destination and transport. Packaging is not included in the sales price.

General sales terms

The products are sold by SERVOMECH S.p.A. according to its **General sales terms** available on our website www.servomech.it or on request to our sales dept. via e-mail (sales@servomech.it). The acceptance of our order confirmation implies also the acceptance of our **General sales terms**.

Bevel gearboxes in lifting systems

Bevel gearboxes are often used in multi-point lifting systems to connect several screw jacks by means of shafts and couplings and to synchronize the lifting linear movement. Following examples are the typical lifting schemes (lay-out):

Lay-out with 2 lifting points

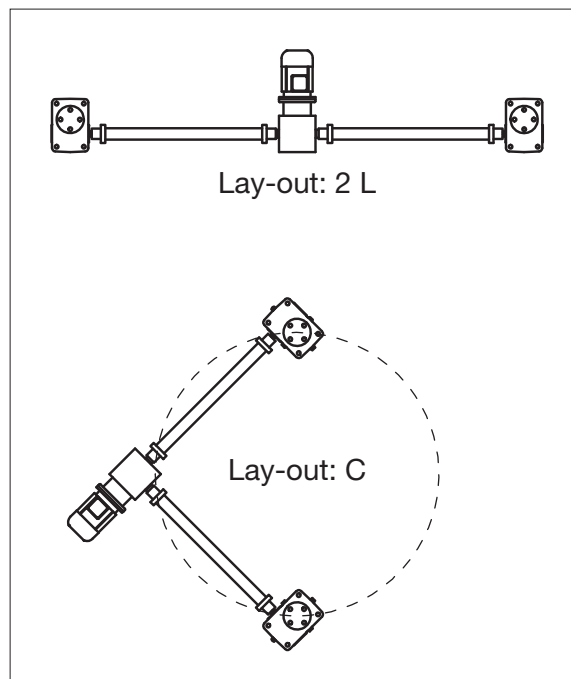

Bevel gearboxes BG Series

Bevel gearboxes in lifting systems

Lay-out with 3 lifting points

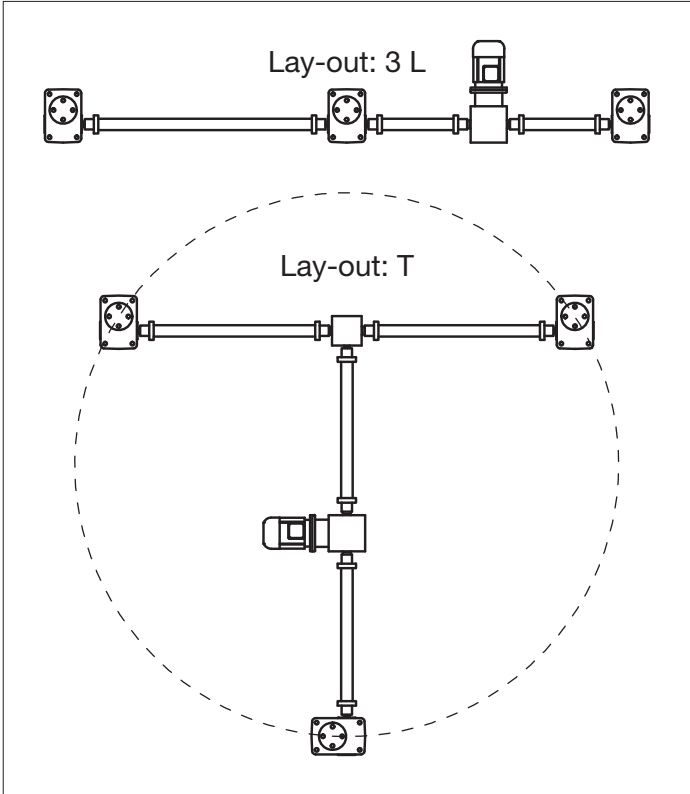

Lay-out with 4 lifting points

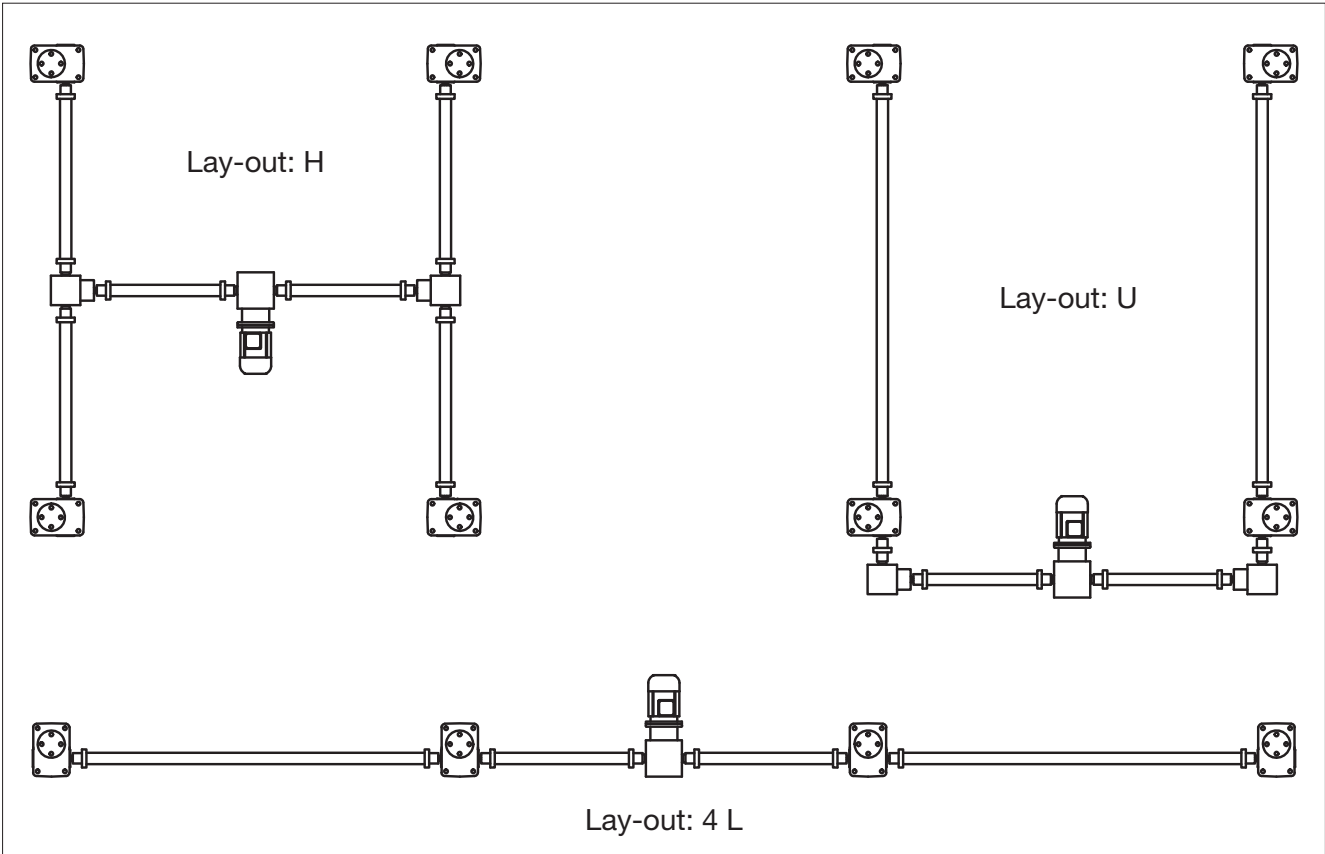

Bevel gearboxes BG Series

Bevel gearboxes in lifting systems

Choice and selection of bevel gearboxes for lifting systems should be done considering not only the lifting speed and load, i.e. the required power, but also and above all the **lay-out type, the distance between the lifting points to be connected and the duty cycle.**

We would like to draw your attention while determining the ratio of different components: gearmotors, bevel gearboxes and screw jacks. The ratio shall be determined in order to achieve the required linear speed while reducing at the same time the shafts' and couplings' rotation speed as much as possible, especially in case of big distance between the points to be mechanically connected.

A reduced speed of shafts and couplings prevents from buckling vibrations and avoids to reach critical rotation speed.

Some indications in case of high lifting speeds:

- screw jacks with high ratio
- acme or ball screws with long lead
- bevel gears with ratio 1 : 1
- gearmotor (depending on the required speed)

This solution allows shafts and couplings to rotate slower, preventing vibrations and noise during operation and improve safety and lifetime of all system components.

In case of big distance between lifting points, it is necessary to support transmission shafts in one or more points.

Do not forget to verify the transmitted torque and rotation speed of shafts and couplings!

The lay-out type obliges to pay attention to:

- direction of rotation of the shafts
- disposal of screw jacks and direction of rotation, lead angle of acme or ball screw
- kinematic schemes of gears inside bevel gearboxes (see pages 30 ... 36)

We recommend to verify the direction of the shaft rotation on the schemes in order to select the right kinematic scheme of the rotation of the bevel gearbox shafts.

Type of working cycle:

Generally, the traditional lifting systems operate with low duty cycle, medium-to-high or heavy load, medium-to-low lifting speed.

Usually, they consist of acme screw jacks, worm or bevel gearmotors (depending on the required ratio), and grease lubricated bevel gearboxes with ratio 1 : 1.

In the last years, more frequently required conditions in industrial lifting applications have been as follows:

- medium-to-high duty cycle
- high lifting speed
- medium-to-light load.

The reason of these requirements has not been only the specific process cycle, but also the general need to reduce energy consumption.

Bevel gearboxes in lifting systems

These modern industrial lifting systems usually consist of:

- high efficiency oil lubricated ball screw jacks
- oil lubricated bevel gearboxes
- oil lubricated bevel gearmotors, with motor driven by inverter or with servomotor

SERVOMECH S.p.A. includes within its product range all components to realize:

- **traditional lifting systems:**
 - grease lubricated acme screw jacks
 - grease lubricated bevel gearboxes
 - grease lubricated bevel gearmotors
- **modern lifting systems with high efficiency and low energy consumption:**
 - oil lubricated ball screw jacks
 - oil lubricated bevel gearboxes
 - oil lubricated bevel gearmotors

On request, connection shafts and couplings can be supplied as commercial products.

SERVOMECH S.p.A. offers to customers a support service for calculation and design of lifting system components, as well as the verification of their compliance with the given specifications or required performances.

Besides calculation and verifications, the service includes the selection of the components, the lay-out drawing and the 3D model of each component, if required.

SERVOMECH product range

Besides bevel gearboxes, the product range of SERVOMECH also includes:

- acme screw linear actuators
- ball screw linear actuators
- acme screw jacks
- ball screw jacks
- ball screws and nuts
 - tolerance grade IT 7, rolled
 - tolerance grade IT 5 – IT 3, whirled

Linear actuators

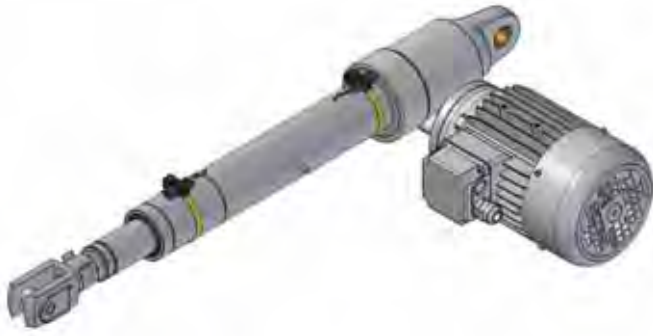

ATL Series with acme screw

- 7 sizes available
- load capacity from 4 kN to 80 kN
- linear speed from 1.5 mm/s to 150 mm/s

BSA Series with ball screw

- 7 sizes available
- load capacity from 4 kN to 60 kN
- linear speed from 1.5 mm/s to 120 mm/s

UAL Series with acme screw

- 5 sizes available
- load capacity from 2 kN to 15 kN
- linear speed from 20 mm/s to 500 mm/s

UBA Series with ball screw

- 5 sizes available
- load capacity from 2 kN to 15 kN
- linear speed from 40 mm/s to 500 mm/s

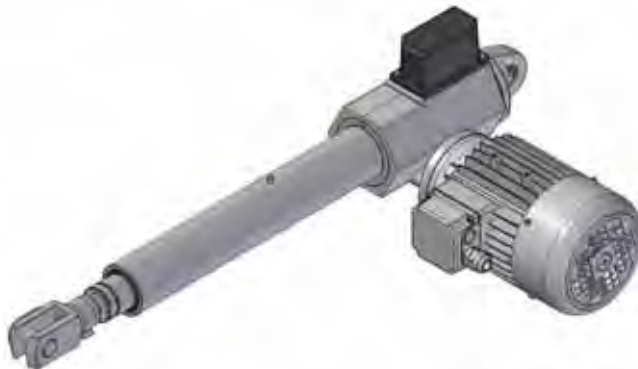
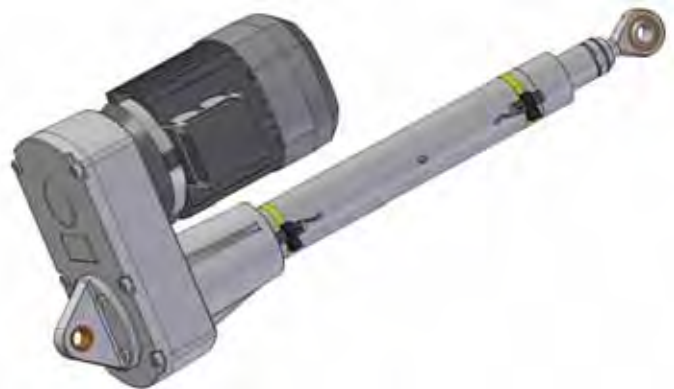

CLA Series with acme screw

- 3 sizes available
- load capacity from 8 kN to 25 kN
- linear speed from 4 mm/s to 56 mm/s

CLB Series with ball screw

- 3 sizes available
- load capacity from 6 kN to 25 kN
- linear speed from 5 mm/s to 80 mm/s

TMA Series with acme screw

- 5 sizes available
- load capacity from 15 kN to 200 kN
- linear speed from 2 mm/s to 70 mm/s

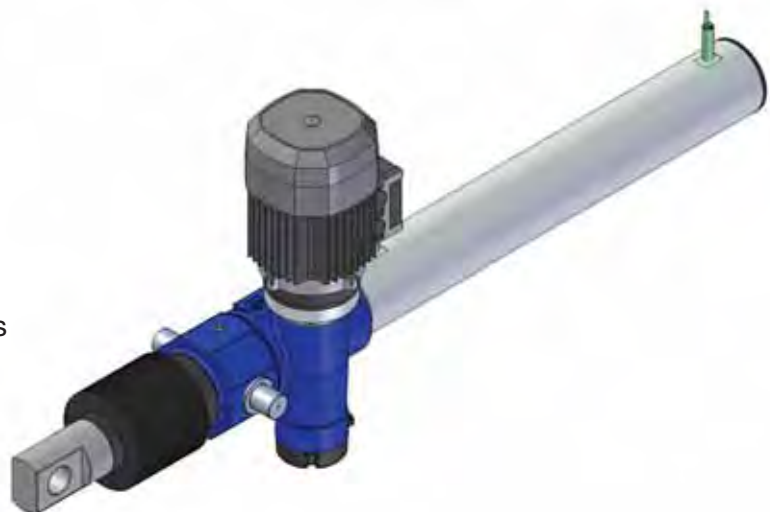

Ball screw jacks

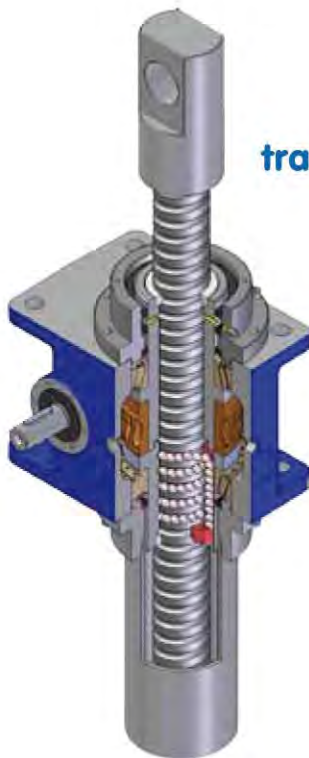

travelling screw

- High performances, accuracy and stiffness. Duty cycle up to 100 % (continuous).
- Design totally patented
- Patented lubrication system ball nut with large grease reserve
- Load capacity from 10 kN to 200 kN

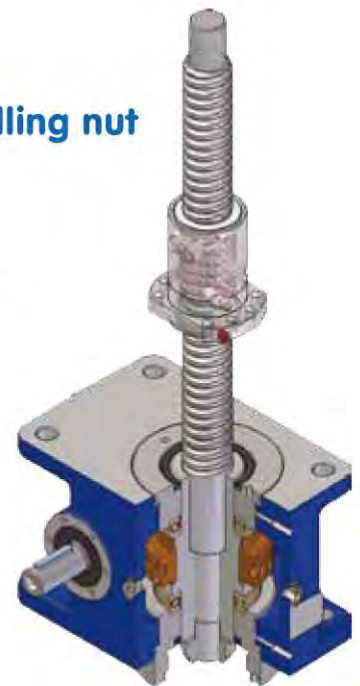

travelling nut

Ball screws and nuts



- Whirled ball screws, accuracy grade IT3 or IT5
- Rolled ball screws, accuracy grade IT7
- Ball nuts with DIN 69051 flange or cylindrical flange
- Backlash-free or preloaded ball nuts

Italian technology

own production

entire in-house manufacturing

Ask for technical catalogues at:
info@servomech.it

Screw Jacks

SERVOMECH Product Range
includes also:

Acme and Ball Screw Jacks

Download it at www.servomech.it
or ask for a free copy to

Phone: + 39 051 6501711

Fax: + 39 051 734574

info@servomech.it

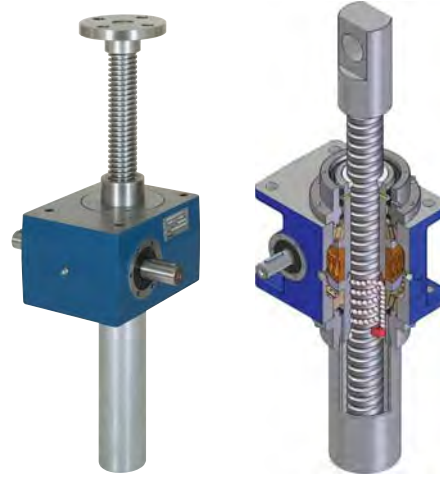

Distributed by:

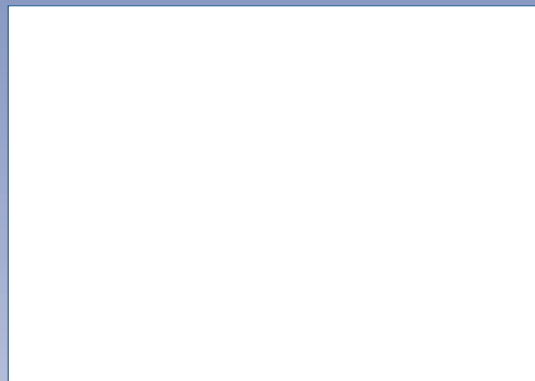

 **Servomech**[®]
new ideas in linear motion

SERVOMECH s.p.a.

Via M. Calari, 1 - 40011 Anzola dell'Emilia (Bologna) - Italy

Tel.: + 39 051 6501711 - Fax: +39 051 734574

www.servomech.it e-mail: info@servomech.it

